



# KRENDL™

The Innovator in Insulation Equipment



## OWNERS MANUAL

### MODEL #5200-TG-A



**65 YEARS OF AMERICAN INGENUITY**

---

KRENDL MACHINE COMPANY • 1201 SPENCERVILLE RD  
DELPHOS, OHIO 45833 • TELEPHONE 800-459-2069 • FAX 419-695-9301  
E - MAIL: [krendl@krendlmachine.com](mailto:krendl@krendlmachine.com) • WEB SITE: [www.krendlmachine.com](http://www.krendlmachine.com)

---

CONGRATULATIONS ON YOUR PURCHASE OF KRENDL EQUIPMENT

**MODEL #5200-TG-A  
OWNER'S MANUAL**

FOR ASSURED SAFETY AND CONFIDENCE, PLEASE READ THIS MANUAL CAREFULLY BEFORE INSTALLING AND OPERATING YOUR MACHINE.

**NOTE:** FAILURE TO READ MANUAL BEFORE INSTALLING EQUIPMENT MAY RESULT IN VOIDED WARRANTY.

**E-MAIL ADDRESS IS: [krendl@krendlmachine.com](mailto:krendl@krendlmachine.com)  
WEB SITE IS: [www.krendlmachine.com](http://www.krendlmachine.com)**

# Table of Contents

INTRODUCTION .....	1
UNPACKING & INSPECTING EQUIPMENT .....	2
GENERAL SAFETY INFORMATION .....	2-5
DECALS .....	5-7
WARRANTY .....	8
RETURNED GOODS PROCEDURE .....	9
SPECIFICATIONS .....	9
BASIC COMPONENTS .....	10
OPERATING INSTRUCTIONS .....	11-13
GENERAL MAINTENANCE .....	14-17
ELECTRICAL SYSTEM .....	18-20
TROUBLESHOOTING .....	21-22
SPARE PARTS LIST .....	22
PARTS LIST .....	23-35
GLOSSARY .....	36
SERVICE RECORD .....	37

## INTRODUCTION

Thank you for purchasing a **KRENDL INSULATION MOVING MACHINE**. With over sixty five years experience in manufacturing insulation moving equipment, we have designed and built your machine with the highest quality parts and workmanship to provide years of reliable service.

This manual has been prepared to help you obtain the maximum efficiency and service from your Krendl equipment. This machine is designed to blow cellulose, fiberglass and rockwool into attics. Our primary objective is to build equipment which will provide complete satisfaction so that you may confidently recommend Krendl to others.

We do not manufacture or sell insulation. Our interest lies only in the proper performance of the equipment we manufacture. The insulation material manufacturer's instructions prevail when it comes to applying their product, since they guarantee the final results.

This manual contains important information regarding the safe assembly and operation of your machine. We urge you to read it carefully and **THOROUGHLY** before putting your machine to work. If your questions are not answered in this manual, please contact us. We want you to be able to operate this equipment safely and confidently.

Upon receipt of this machine, check it carefully for any shipping damage. If there is damage or if any of the parts are missing, notify the delivery trucking company immediately and file a claim for damages, saving all packaging materials for inspection. Our warranty covers manufacturer's defects only. If Krendl Machine Company delivered or set up your machine and any parts are missing or damaged, notify the authorized representative before they leave.

Krendl Machine Company  
1201 Spencerville Rd  
Delphos, Ohio 45833 U.S.A.

Telephone: 800-459-2069  
Fax: 419-695-9301  
E-Mail: [krendl@krendlmachine.com](mailto:krendl@krendlmachine.com)  
Web Site: [www.krendlmachine.com](http://www.krendlmachine.com)

For your protection in the event of theft or loss, please fill in the information requested for your own records. This information will be needed for in-warranty repairs. You may also want to attach a copy of your invoice.

Machine Model No. \_\_\_\_\_

Machine Serial No. \_\_\_\_\_

Engine Manufacturer \_\_\_\_\_

Engine Model No. , Serial No. \_\_\_\_\_

Blower Manufacturer \_\_\_\_\_

Blower Model No., Serial No. \_\_\_\_\_

Blower Clutch Manufacturer \_\_\_\_\_

Blower Clutch Model No., Serial No. \_\_\_\_\_

Airlock Clutch Manufacturer \_\_\_\_\_

Airlock Clutch Model No., Serial No. \_\_\_\_\_

## UNPACKING AND INSPECTING EQUIPMENT

### RECEIVING YOUR MODEL #5200-TG-A KRENDL MACHINE:

Immediately check the condition of your Model #5200-TG-A machine when it is received. It should be received in the same condition that it was shipped to you. **If there are any visible problems with your machine or any other items in the shipment, it is imperative that you place any claim with the delivery carrier.** Please save all packaging materials for inspection. The delivery carrier should also contact our office before leaving the premises to notify us of a claim. The ownership to your machine and all other items in the shipment were transferred to your name as soon as the shipment left our premises, thus it is your responsibility to contact us with any claims. Contact the truck line to arrange for an independent inspector to come out to inspect the damage and to prepare the inspection report. It is imperative that this inspection is done prior to unpacking or using any of the equipment. Please contact us for assistance or with any questions you may have regarding the claim process.

### UNPACKING:

Handle all cartons with care to avoid damage from dropping or bumping. Completely remove machine from the packaging and from any shipping pallet or skid to which it might be attached. In addition, completely remove all shipping materials from inside the machine. Check that all parts are included as stated on the list below.

### ACCESSORIES INCLUDED:

- 150' REMOTE CONTROL CORD
- MULTIMETER
- SPANNER WRENCH FOR BELT TENSIONERS
- #60 CHAIN MASTER LINK
- SECTION OF CHAIN FOR CHANGING SHREDDER DIRECTION
- 5/16 ALLEN WRENCH FOR ADJUSTMENT OF CHAIN IDLERS
- EXHAUST SYSTEM FOR ENGINE MODELS ONLY
- OWNERS MANUAL

## GENERAL SAFETY INFORMATION



**Important:** Read **all** instructions **before** operating this equipment. This equipment can be potentially dangerous and must be used in strict accordance with instructions.



**Disclaimer Notice:** The manufacturer will not be legally responsible for any injury or damage resulting from the improper use of this equipment or the failure to follow instructions.

### Unpacking

Handle cartons with care to avoid damage from dropping or bumping. Completely remove the machine from the packaging and from any shipping pallet or skid to which it may be attached. In addition, completely remove all shipping materials from the **inside** of the machine.



**Important:** Please recheck inside the hopper for any loose items or damaged equipment. Injury may occur when equipment is started with foreign material in the hopper.

**General Safety**

1. Read this manual carefully and become familiar with your machine. It is important to know its applications, limitations, and any hazards involved prior to operating the machine.
2. This machine was designed and manufactured for blowing cellulose, fiberglass and mineral fiber. Do not attempt to modify the unit or use it for any application it was not designed for. If you have any questions about your intended use or the machine's suitability, ask your dealer/distributor or consult the factory. The manufacturers could not possibly anticipate every circumstance that might involve a hazard. For that reason, warnings in the manual and warning tags or decals affixed to the unit, are not all-inclusive. If you intend to handle, operate, or service the unit by a procedure or a method not specifically recommended by the manufacturer, first make sure that such a procedure or method will not render this equipment unsafe or pose a threat to you and others.
3. Do not disable any of the safety features on the equipment. These features are for your protection and safety.
4. Read and obey all safety and operating instructions in the manual and on the machine.
5. Equipment is to be operated and/or maintained by TRAINED & QUALIFIED personnel ONLY!!
6. **BEFORE PERFORMING ANY MAINTENANCE ON THE MACHINE, YOU MUST FIRST:**
  - #1 TURN THE DISCONNECT SWITCH TO THE "OFF" POSITION
  - #2 DISENGAGE PTO AND TURN THE TRUCK OFF
  - #3 TURN THE IGNITION TO THE "OFF" POSITION AND REMOVE KEY
7. Do not operate the machine without all guards and safety equipment installed in the proper location and in working order. Always follow the proper shut down procedures outlined in Item 6 when guards are removed from the machine or when compartment or electrical control doors need to be opened.
8. If a malfunction occurs while running the machine, turn it off immediately, follow the directions under item 6 and correct the problem prior to restarting the machine.
9. Keep body and all clothing away from rotating equipment. Rotating shafts can be dangerous.
10. Always wear proper safety equipment when operating the machine. This includes steel toed shoes, safety glasses and a respirator.
11. Under no circumstances should your hand, a stick or a broom be used to force material down into the hopper. The machine is a self feeding design and requires no outside assistance.
12. Stand on the floor, not a platform while operating the machine. The operator may lose balance and fall while loading bags of material.

All Model #5200 Machines are factory equipped with side, front, and main drive belt guards. The top of the machine is not guarded since it poses no safety threat for normal insulation blowing operations.

Always turn the main power switch (located on the electrical box) to off and unplug the remote cord from the receptacle for any type of machine maintenance or adjustments. An additional safety feature is the ability to adjust the material slide gate from the outside of the machine. Rotate the adjustment handle clockwise to open the slide to the desired setting, no entrance into the machine is required.

**All safety features are incorporated into the machine to protect everyone from serious injury. Operate your machine according to the outlined instructions in the manual with all guards in place and securely latched. Operation with any guards removed can result in injury to or loss of fingers, hands, arms, toes, feet, legs, hair, and even your eyes.**

**Electrical Safety**

- The **National Electric Code** (NEC) in the United States and many international electrical codes require frame and external electrically conductive parts of this machine to be properly connected to an approved earth ground. Local electrical codes may also require proper grounding of machine. Consult with local electricians for grounding requirements in your area.
- Never handle any kind of electrical cord or device while standing in water, while barefoot or while hands or feet are wet. Dangerous electrical shock will result.
- Use a ground fault circuit interrupter (GFCI) in any damp or highly conductive area. (metal decking or steel work)
- Reference NFPA 79, 70E, or OSHA safe work practices when performing energized work procedures.

**Safety/Caution**

- **Be Safe** - Keep away from moving parts.
- **Be Safe** - Make sure all guards and hopper extensions are in proper place **before** operating machine. Guards and safety devices/switches should not be removed, modified or by-passed. Hands should never pass between rotating parts.
- **Be Safe** - Make sure the main disconnect switch, remote control hand pendant switch and four position selector switch are all in the **off** position **before** operating the machine.
- **Be Safe** - Protect all electrical supply cords from sharp objects, moisture, and other potentially hazardous materials. Keep power cords in good repair. Electrical service must be performed by a qualified electrician.
- **Be Safe** - Disengage PTO, turn truck off and remove key **before** inspecting or adjusting unit.
- **Be Safe** - Consult a qualified technician to answer questions **before** attempting to operate, or injury may result.
- **Be Safe** - **Emergency Kill Switch** - In case of emergencies, always use red stop button located on the front of Main Control Panel and on the side of the hopper. It will stop all feeding and agitation.
- **Be Safe** - Do not remove motors or lift hopper when unit is connected to power supply.
- **Be Safe** - Do not operate machine alone.
- **Be Safe** - Do not leave machine unattended and energized.
- **Be Safe** - Turn machine off and disconnect electricity before clearing and feeding jam or attempting to remove any object dropped in the hopper.
- **Be Safe** - Keep hands, loose clothing, jewelry and hair away from agitators, gears, chains and other moving parts.
- **Be Safe** - Use proper lifting when moving insulation and loading machine.
- **Be Safe** - Keep work area clear of debris.
- **Be Safe** - Wear proper safety equipment, including protective gear, such as respirators, eye and ear protection.
- **Be Safe** - Violation of the Owner's Manual or safety precautions may void warranty.

## Make Sure!

- Hopper is empty of foreign objects **before** starting.
- Adequate electrical power is supplied or damage to unit will result.
- Machine must be on **before** adding insulation.
- Blower filter is kept clean and in place when blower is on.
- Machine is turned off **immediately** if hose is plugged, or blower will overheat.
- Blower must be on, when agitators are running, or machine will bind.
- Agitator motor is not run with hopper empty for more than a few minutes, or damage to seals will result.
- Sprockets, chains, belts and pulleys are correctly **aligned** and **tensioned**.
- Pieces of bag are **not** left in the machine as this can bind and stall your machine.
- This machine should only be used with good quality insulations that are dry, undamaged and that meet a certain industry specification or quality standards.

**IF THERE ARE ANY QUESTIONS WITH YOUR KRENDL MACHINE, DO NOT HESITATE TO CONTACT US AT: 1-800-459-2069**

## DECALS

**ALL FIBER MACHINES**

IMPORTANT: READ ALL INSTRUCTIONS BEFORE OPERATING THIS UNIT. THIS EQUIPMENT CAN BE POTENTIALLY DANGEROUS AND MUST BE USED IN STRICT ACCORDANCE WITH INSTRUCTIONS.

DISCLAIMER NOTICE: THE MANUFACTURER WILL NOT BE LEGALLY RESPONSIBLE FOR ANY INJURY OR DAMAGE RESULTING FROM THE IMPROPER USE OF THIS EQUIPMENT OR THE FAILURE TO FOLLOW INSTRUCTIONS. (REFER TO ADDITIONAL INSTRUCTIONS PROVIDED.)

**SAFETY - CAUTION**

- BE SAFE** - KEEP AWAY FROM MOVING PARTS.
- BE SAFE** - MAKE SURE ALL GUARDS AND HOPPER IS BARS ARE IN PROPER PLACE BEFORE OPERATING MACHINE. HANDS SHOULD NEVER PASS BELOW HOPPER OR BARS.
- BE SAFE** - MAKE SURE BLOWER MOTOR AND AGITATOR MOTOR SWITCHES ARE IN OFF POSITION BEFORE CONNECTING THE POWER SUPPLY TO THE MACHINE.
- BE SAFE** - MAKE SURE MACHINE IS PROPERLY GROUNDED. PROTECT POWER CABLE FROM SHARP OBJECTS, MOISTURE, AND OTHER POTENTIALLY HAZARDOUS MATERIALS. KEEP POWER CABLES IN GOOD REPAIR. ELECTRICAL SERVICES MUST BE PERFORMED BY A QUALIFIED ELECTRICIAN.
- BE SAFE** - DISCONNECT POWER BEFORE ADJUSTING OR ALIGNMENT TO UNIT.
- BE SAFE** - DO NOT REMOVE BLOWER OR HOPPER WHEN UNIT IS CONNECTED TO POWER SUPPLY.
- BE SAFE** - CONSULT A QUALIFIED PERSON TO ANSWER QUESTIONS BEFORE ATTEMPTING TO OPERATE, OR FAILURE MAY BE LETHAL.

**IMPORTANT**

MAKE SURE - ADEQUATE ELECTRICAL POWER IS SUPPLIED OR DAMAGE TO UNIT WILL RESULT.

MAKE SURE - BLOWER FILTER IS KEPT CLEAN AND IN PLACE WHEN BLOWER IS ON.

MAKE SURE - BLOWER IS ON WHILE AGITATOR IS RUNNING, OR MACHINE WILL BIND.

MAKE SURE - BLOWER IS TURNED OFF IMMEDIATELY IF HOSE IS PLUGGED, OR BLOWER WILL OVERHEAT.

MAKE SURE - AGITATOR MOTOR IS ON BEFORE ADDING FIBER.

MAKE SURE - AGITATOR MOTOR IS NOT RUN WITH HOPPER EMPTY FOR MORE THAN A FEW MINUTES, OR DAMAGE TO SEALS WILL RESULT.

MAKE SURE - BELTS OR CHAINS ARE CORRECTLY ALIGNED AND TENSIONED.

**TODAS LAS MÁQUINAS DE FIBRA**

IMPORTANTE: ES IMPORTANTE LEER TODAS LAS INSTRUCCIONES ANTES DE OPERAR ESTA UNIDAD. ESTE EQUIPO PUEDE SER POTENCIALMENTE PELIGROSO Y SE DEBE USAR ESTRICTAMENTE DE ACUERDO CON LAS INSTRUCCIONES.

AVISO DE RESPONSABILIDAD LEGAL: EL FABRICANTE NO SERÁ LEGALMENTE RESPONSABLE POR NINGÚN PERJUICIO O DAÑO RESULTANTE POR EL USO INAPROPIADO DE ESTE EQUIPO O LA INDEBERENGA DE LAS INSTRUCCIONES. (CONSULTE A LAS INSTRUCCIONES ADICIONALES SUMINISTRADAS.)

**SEGURIDAD - PRECAUCIÓN**

- NO CORRER RIESGO** - MANTÉNTESE AJUSTADO DE LAS PARTES EN MOVIMIENTO.
- NO CORRER RIESGO** - ASEGÚRESE DE QUE TODAS LAS PROTECCIONES Y LAS BARRAS DE LA TOLVA ESTÉN EN EL LUGAR CORRECTO Y ANTES DE OPERAR LA MÁQUINA. LAS MANOS JAMÁS DEBEN PASAR POR DEBAJO DE LAS BARRAS DE LA TOLVA.
- NO CORRER RIESGO** - ASEGÚRESE DE QUE LOS INTERRUPTORES DEL MOTOR DEL SOPLADOR Y DEL AGITADOR ESTÉN EN LA POSICIÓN OFF ANTES DE CONECTAR EL SUMINISTRO DE ENERGÍA A LA MÁQUINA.
- NO CORRER RIESGO** - ASEGÚRESE DE QUE LA MÁQUINA ESTE PUESTA A TIERRA ADECUADAMENTE. PROTEJA EL CABLE DE ENERGÍA DE OBTUSOS CONTACTOS, HUMEDAD Y OTROS MATERIALES POTENCIALMENTE PELIGROSOS. CONSERVA LOS CABLES DE ENERGÍA EN BUENA FORMA. EL MANTENIMIENTO ELÉCTRICO DEBE SER A CARGO DE UN ELECTRICISTA CALIFICADO.
- NO CORRER RIESGO** - DESCONECTE EL SUMINISTRO DE ENERGÍA ANTES DE ADJUSTAR O AJUSTAR LA UNIDAD.
- NO CORRER RIESGO** - NO DEJE EL SOPLADOR O LA TOLVA CUANDO LA UNIDAD ESTÁ CONECTADA AL SUMINISTRO DE ENERGÍA.
- NO CORRER RIESGO** - CONSULTE A UNA PERSONA CALIFICADA ANTES DE INTENTAR OPERAR LA MÁQUINA O SI ALGUNO PUEDE LESIONARSE.

**IMPORTANTE**

ASEGÚRESE DE - QUE SE SUMINISTRE LA ENERGÍA ELÉCTRICA ADECUADA O SE DAÑARÁ EL EQUIPO.

ASEGÚRESE DE - QUE EL FILTRO DEL SOPLADOR SE MANTIGA LIMPIO Y EN SU LUGAR CUANDO EL SOPLADOR ESTÁ EN FUNCIONAMIENTO.

ASEGÚRESE DE - QUE EL SOPLADOR FUNCIONE SIEMPRE EL AGITADOR ESTÁ EN MARCHA, O LA MÁQUINA SE PARARÁ.

ASEGÚRESE DE - QUE EL MOTOR DEL AGITADOR NO SE EJECUTE ANTES DE QUE SE HAYA PUESTO EL SOPLADOR EN MARCHA.

ASEGÚRESE DE - QUE EL MOTOR DEL AGITADOR NO FUNCIONE CON LA TOLVA VACÍA MÁS QUE UNOS POCOS MINUTOS O SE DAÑARÁN LOS SELLOS.

ASEGÚRESE DE - QUE LAS CORREAS O CADENAS ESTÉN CORRECTAMENTE ALINEADAS Y TENSIONADAS.

**LISTED  
ELECTRIC  
CABINET  
BOX**

Issue No. XXXXXXXX

E314782

Krendl Machine Co.  
1201 Spencerville Ave.  
Delphos, OH 45833

**TYPE 1  
Indoor Use**

Indicates that the electrical box on the machine is in compliance with UL codes.

**INSPECTED  
BY**

Indicates which employee inspected equipment and on what date.

**FEED  
BLOWER OFF BLOWER**

Indicates if blower is off, on, or on with agitator.

General safety information intended to reduce the risk of serious injury or death

**ELECTRICAL MAINTENANCE**

Krendl Machine Company, 1201 Spencerville Ave, Delphos, OH 45833 PH: 419-662-3060 Fax 419-695-6301

**Daily:**

1. Make sure main disconnect is off before turning generator on.
2. Turn main disconnect switch off before turning generator off.

**Monthly:**

1. Check for loose wire connections on main disconnect switch and tighten with screw driver.
2. Check for loose wire connections in electrical box and tighten with screw driver.

---

**MANTENIMIENTO ELÉCTRICO**

Krendl Machine Company, 1201 Spencerville Ave, Delphos, OH 45833 PH: 419-662-3060 Fax 419-695-6301

**Diariamente:**

1. Asegúrese de que el interruptor principal esté abierto antes de conectar el generador.
2. Abra el interruptor principal antes de desconectar el generador.

**Mensualmente:**

1. Verificar que no haya conexiones flojas en el interruptor principal y ajustarlas con un destornillador.
2. Verificar que no haya conexiones flojas en el tablero eléctrico y ajustarlas con un destornillador.

Electrical maintenance information and schedule provided here.





Keeping the filter clean will result in longer blower life and better performances.



Keeping the door closed will keep bystanders safe from rotating parts.



Rotating parts can be dangerous! You can snag clothes, skin, hair, hands, etc. This can cause serious injury or death.



Emergency stop button for machine.



Monthly maintenance schedule for the greasing of bearings on the agitators, shredders and airlock bearings.



Opens and closes the material feed gate which in turn controls the production.

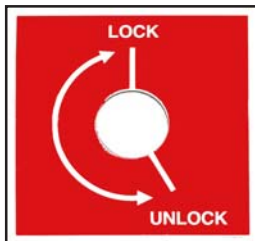

Indicates if the latches on the access door are locked or unlocked



Identifies air adjustment control.



Made in the U.S.A.

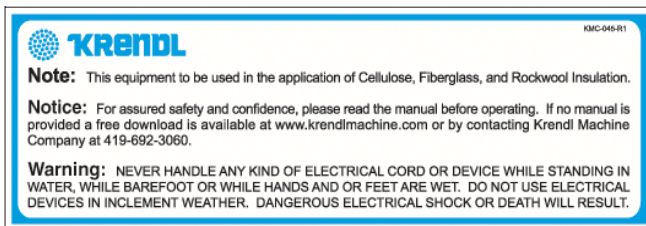

Identifies what type of insulation should be used with this machine and that the manual should be read before operating. Warns to be careful around electrical components! This can cause serious injury or death.



Operating machine at specified voltage will result in longer machine life and better performance.



Identifies position of material feed gate.



Part number for identification and tracking.

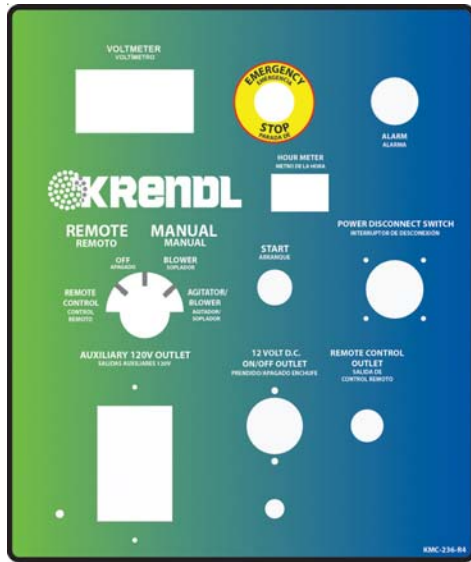

Indicates the controls that start, stop, and run the machine.

### BLOWER MAINTENANCE

Krendl Machine Company, 1201 Spencerville Ave, Delphos, OH 45833 PH: 419-692-3000 Fax: 419-695-0301

**Weekly:**  
1. Remove blower filter and blow with compressed air to clean, replace filter if needed.

**Monthly:**  
1. Check blower motor pulley and belt tension.  
2. Check oil (SBC-430) level/ change after first 100 hrs. and every 1000 hrs. thereafter.  
3. Grease blower module with high speed grease (Mobilith AW2 Industrial).

**Yearly:**  
1. Grease shaft end bearing on motor with high speed grease (Mobilith AW2 Industrial).

### MANTENIMIENTO DEL SOPLADOR

Krendl Machine Company, 1201 Spencerville Ave, Delphos, OH 45833 PH: 419-692-3000 Fax: 419-695-0301

**Semana:**  
1. Quitar el filtro del soplador y soplar con aire comprimido para limpiarlo o reemplazar el filtro si fuese necesario.

**Mensual:**  
1. Verificar la polea del motor del soplador y el tensado de la correa.  
2. Comprobar el nivel/cambio del aceite (SBC-430) después de las primeras 100 horas y de cada 1000 horas después de eso.  
3. Módulo del soplador de la grasa con la grasa de alta velocidad (Mobilith AW2 Industrial).

**Anualmente:**  
1. Engrasar el extremo del eje concerninge el motor con la grasa de alta velocidad (Mobilith AW2 Industrial).

Blower maintenance information and schedule provided here.

### PTO MAINTENANCE

Krendl Machine Company, 1201 Spencerville Ave, Delphos, OH 45833 PH: 419-692-3000 Fax: 419-695-0301

**Weekly:**  
1. Grease PTO shaft bearings with high speed grease (Mobilith AW2 Industrial).

**Monthly:**  
1. Check PTO pulley, belt tension and alignment.  
2. Reighten nuts on PTO gear housing, which can loosen due to vibration.  
Note: One hour on hour meter is equivalent to 38 miles on engine odometer.

### MANTENIMIENTO DEL PTO

Krendl Machine Company, 1201 Spencerville Ave, Delphos, OH 45833 PH: 419-692-3000 Fax: 419-695-0301

**Semana:**  
1. Cojinetes de eje de PTO de la grasa con la grasa de alta velocidad (Mobilith AW2 Industrial).

**Mensual:**  
1. Verificar la polea de la toma de fuerza y el tensado de la correa.  
2. Repretar las tuercas en el cárter de engranaje PTO, que pueden aflojarse, debido a la vibración.  
NOTA: Una hora en un medidor de hora es equivalente a 38 millas en un odómetro de máquina.

PTO maintenance information and schedule provided here.

KREN DL The Innovator in Insulation Equipment		KREN DL The Innovator in Insulation Equipment	
GENERAL MAINTENANCE 5200 PTO MACHINE		Mantenimiento general de la máquina de la TDF 5200	
DESCRIPTION	EACH SHIFT	40 hrs.	80 hrs.
MAKE SURE MAIN DISCONNECT IS OFF BEFORE TURNING PTO ON.	X		
TURN MAIN DISCONNECT SWITCH OFF BEFORE TURNING PTO OFF.	X		
CHECK GUARDS.	X		
CHECK TRUCK FLUID LEVELS.	X		
CHECK DRIVE ALIGNMENT & TENSION.		X	
VISUALLY INSPECT COUPLING ELEMENTS FOR FATIGUE CRACKS (EVER 1/2").		X	
CLEAN BLOWER AIR FILTER.		X	
CHECK BLOWER OIL LEVEL.		X	
OPTIONAL VACUUM — GREASE VACUUM SHAFT BEARINGS.		X	
GREASE BLOWER BEARINGS.		X	
LUBRICATE DRIVE CHANG WITH A DRY LUBRICANT.		X	
GREASE SWAYDOL, AIRLOCK, AGITATOR & JACK SHAFT BEARINGS.		X	
CHECK FOR LOOSE WIRE CONNECTIONS ON MAIN DISCONNECT SWITCH, ELECTRICAL BOX & PLUGS WITH SCREW DRIVER.		X	
CHANGE BLOWER OIL.		X	

Machine maintenance information and schedule provided here.

### RECOMMENDED MACHINE SETTINGS KREN DL 5200: OPEN BLOW

Recomienda la configuración de la máquina

INSULATION PRODUCTION	AW-BLEED SET-UP	SHREDDER SETUP	BLK-GATE SETTINGS	DENSITY SETTING	DENSITY SETTING	PRODUCTION RATE	BAGS PER HOUR
GREENFIBER 500	2.0 - 3.0	CENTER DOWN	9	1.38	1.28	5,360	179
GREENFIBER S15	2.0 - 3.0	CENTER DOWN	9	1.37	1.27	5,320	177
JM CLIMATE PRO	1.0 - 1.5	CENTER DOWN	11	0.68	0.47	2,600	87
CERAMTEK INSULSAFE SP	1.0 - 1.5	CENTER DOWN	11	0.45	0.47	2,560	85
KNAUF JET STREAM	1.0 - 1.5	CENTER DOWN	11	0.51	0.51	2,440	81
GUARDIAN SUPER CLUE I	1.0 - 1.5	CENTER DOWN	12	0.50	0.54	2,480	83
OWENS CORNING L77	1.0 - 1.5	CENTER DOWN	11	0.60	0.52	2,720	91
APPLIGATE UNBLENDED	2.5 - 3.0	CENTER DOWN	9	1.28	1.24	5,360	218
APPLIGATE LOOSE FILL	2.5 - 3.0	CENTER DOWN	9	1.08	1.05	4,840	197

Recommended machine settings are provided here for running insulation from different manufacturers.



Rotating parts will be moving in this direction.

The Innovator in Insulation Equipment

Serial No: \_\_\_\_\_

ENGINEERED & BUILT BY  
**KREN DL MACHINE COMPANY**  
1201 SPENCERVILLE AVE., DELPHOS, OH 45833 PH: 419-692-3000 + 800-459-2069  
EMAIL: krendl@krendlmachine.com

## Model 5200

Manufacturer information is provided here along with machine model, and serial number.



During operation, this machine is loud. Wear hearing protection. Failure to do this could result in hearing loss.

**WARRANTY:**

Krendl Machine Company (Company) warrants to each original purchaser (Buyer) of its machines that such products will be free of manufacturing defects for a period of 2 years from the date of shipment to the Buyer. (This does not include accessories, pumps, blowers, wall scrubbers, etc.)

No warranty is made with respect to:

1. Components or accessories manufactured and warranted by others. Warranties for purchased component parts as supplied from vendor such as engine, electric motor, blower, gearbox, transmission, etc., if furnished by the manufacturer of the component, are on file at the Company's main office and copies will be furnished at request of Buyer. Component(s), shipping costs prepaid, shall be sent to Company who in turn shall forward to vendor for evaluation and warranty determination.
2. Any defect caused by repair, alteration and/or adjustment performed by Buyer or customer/vendor of Buyer without the express written authorization of the Company.
3. The labor costs of replacing parts by parties other than the Company.
4. Any machine that has not been operated and/or maintained in accordance with normal industry practice and the written recommendations of the Company. (e.g. machine operated with an improperly sized, worn or damaged hose, improper or inattention to preventative maintenance, etc.)
5. The product has been subjected to misuse, negligence or accident or results of any application or use of the blowing equipment not in accordance with the Company recommendations.

This limited warranty does not cover the free replacement of component parts that become inoperative due to wear and usage and need to be replaced on a regular basis, including but not limited to: airlock seal(s), agitator(s), shredder(s), auger(s), fuse(s), switch(es), clutch(es), hose(s), shaft seal(s), chain(s), belt(s), sprocket(s), pulley(s), bearing(s), cable(s), battery(ies), filter(s), fan(s), etc.

The Company's obligation under this warranty is limited to repairing or replacing (at Company option) any part that is determined by the Company to be suffering from a manufacturing defect. The Company (at Company option) will provide any required parts and labor to the Buyer. If the equipment or parts must be returned to the Company for repair, all transportation costs shall be the Buyer's responsibility.

**THIS LIMITED WARRANTY IS EXPRESSLY IN LIEU OF ANY OTHER GUARANTEES AND / OR WARRANTIES, ORAL OR WRITTEN, EXPRESSED OR IMPLIED, INCLUDING WITHOUT LIMITATION, THE IMPLIED WARRANTY OF MERCHANTABILITY. NO WARRANTY, EXPRESS OR IMPLIED, OTHER THAN THE AFORESAID WARRANTY IS MADE OR AUTHORIZED BY COMPANY. COMPANY SHALL NOT BE LIABLE FOR ANY DIRECT, INDIRECT, INCIDENTAL OR CONSEQUENTIAL DAMAGES TO PROPERTY OR INJURY TO ANY PERSON OR COSTS ASSOCIATED WITH LOSS OF PRODUCTION RESULTING IN LOSS OF REVENUE, PROFITS OR LOSS OF EQUIPMENT THROUGH THE USE OF THIS EQUIPMENT.**

**Note: Special job circumstances incurring costs for specialized repair and next day delivery of parts will not be reimbursed by the manufacturer unless authorized by factory.**

## RETURNED GOODS PROCEDURE

IF MACHINE WAS NOT PURCHASED DIRECTLY FROM KRENDL MACHINE COMPANY, CONTACT YOUR SUPPLIER / DISTRIBUTOR.

When returning products to Krendl for repair, first obtain a return goods authorization (RGA), at which time you will be given shipping instructions. The product must be shipped **PREPAID**:

**Krendl Machine Company**  
1201 Spencerville Rd  
Delphos, Ohio 45833 U.S.A.

Telephone: 800-459-2069  
Fax: 419-695-9301  
E-mail: [krendl@krendlmachine.com](mailto:krendl@krendlmachine.com)  
Web Site: [www.krendlmachine.com](http://www.krendlmachine.com)

Once the unit is received, it will be inspected. In-warranty units will be repaired and returned immediately. An estimate of repair charges will be provided for out-of-warranty units.

## SPECIFICATIONS

<b>MODELS:</b>	#5200-TG-A
<b>MACHINE:</b>	14" Diameter x 18" Length airlock feeder electromagnetic clutches on agitator and blower in line helical gearbox (driving the machine)
<b>HEIGHT:</b>	83" (211 cm)
<b>LOAD HEIGHT:</b>	63.25 inches
<b>WIDTH (DEPTH):</b>	52" (132 cm)
<b>LENGTH:</b>	76" (193 cm)
<b>WEIGHT:</b>	1725 pounds (783 kg)
<b>ELECTRICAL:</b>	12VDC remote control system <b>(14.4 KVA generator supplying 120VAC to convenience outlets &amp; accessories)</b>
<b>BLOWER VOLUME:</b>	250 CFM
<b>BLOWER PRESSURE:</b>	6.0 PSI maximum
<b>HOSE OUTPUT:</b>	4" diameter
<b>MAXIMUM FEED RATES:</b>	
<i>CELLULOSE:</i>	5200 lbs./hr. (2359 kg/hr) 175 bags per hour
<i>FIBERGLASS:</i>	2300 lbs./hr (1043 kg/hr) 80 bags per hour

**WARNING: Recommended hose size, type and length must be used to achieve maximum results. Krendl cannot guarantee performance of the #5200-TG-A machine if hoses are undersized, worn, damaged, or hoses other than those we recommend are used.**

**BEFORE YOU RUN THIS MACHINE...PLEASE READ THE REST OF THIS MANUAL!!**

**BASIC COMPONENTS**

This is a view of the basic components of your Model #5200-TG-A machine. It shows the location of each item and gives the function of each. Use this as a guide throughout the manual.

**(Illustration 1)**

- A) Base Unit** - Lower frame unit supporting blower, speed reducer, motor, airlock and hopper.
- B) Airlock** - Traps air and fiber while providing a metered flow.
- C) Shredder System** - Increases production and coverage on all insulation products while reducing clumps that may exist in various insulations.
- D) Slidegate** - Meters the amount of insulation dropping into the airlock by controlling size of airlock opening.
- E) Speed Reducer** - Increases output power while decreasing speed of agitator/airlock drive motor.
- F) Agitator** - Conditions insulation in the hopper.
- G) Hopper** - Upper unit of machine holding insulation.
- H) Gear Drive** - Provides driving power for blower, speed reducer, and generator.

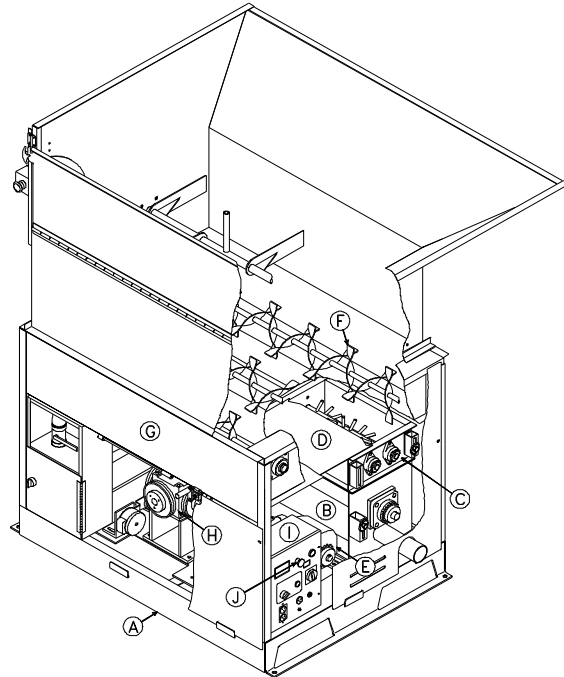
**Illustration 1****(Illustration 2)**

- I) Main Control Panel** - Connects with main power, allowing operation of unit at machine or Remote Cord.
- J) Kill Switch** - Safety device for immediate stopping of machine.
- K) Blower** - Provides the air necessary to move insulation from the airlock.
- L) Generator** - Provides power to all auxiliary electrical components.
- M) Hopper Extension** - Increases overall hopper capacity.

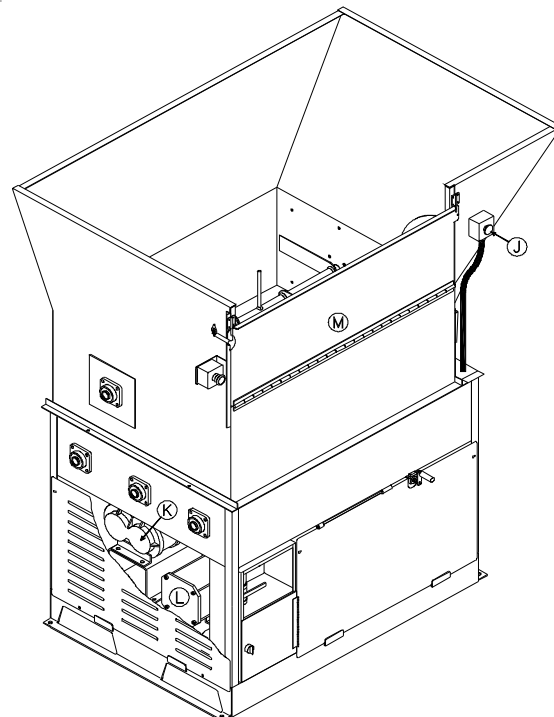
**Illustration 2**

## OPERATING INSTRUCTIONS

### Starting Your Krendl Model 5200-TG-A Machine:



- 1) Make sure truck is on level ground, parking brake is engaged and wheels are chocked.
- 2) Attach the blowing hose to the machine and fasten with clamps.
- 3) Make sure the control toggle switch on the remote control cord is in the OFF position. Now, you may plug in the remote control cord.
- 4) Make sure the four position switch and main disconnect switch on the electrical panel are in the OFF position.
- 5) Turn truck ignition ON and start truck. Let engine run at idle.
- 6) Engage PTO by depressing red rocker switch to ON position. (Switch will illuminate.)
- 7) Depress cruise control ON, then depress SET. This will automatically increase engine idle and maintain idle for blowing application.
- 8) Your machine is now ready for operation.

### Electrical Operation:

**NOTE: PRESS KILL SWITCH TO IMMEDIATELY STOP MACHINE AT ANY TIME!**

1. Make sure Kill Switch is out by pulling. (See illustration 3) (Located on hopper and electrical panel.)
2. Turn *red* Main Disconnect Switch to ON position. (See illustration 3)
3. Set 4-Position Selector Switch to OFF. (See illustration 3)
4. Press *green* start Button. **Machine will not run unless start button is pressed *after* Kill Switch is out and *red* Main Disconnect Switch is on.** (See illustration 3)
5. Select operating mode on 4-Position Selector Switch from one of the following options:

- |                              |  |
|------------------------------|--|
| <b>Remote:</b>               | Remote control hand pendant will control machine.  |
| <b>Off:</b>                  | Machine will not run. (overrides remote hand pendant)                                    |
| <b>Blower:</b>               | Only the blower will run continuously. (manual control at machine)                       |
| <b>Agitator-Feed/Blower:</b> | Both the blower and the agitator-feed will run continuously. (manual control at machine) |

**Main Control Panel (lid closed)  
Illustration 3**

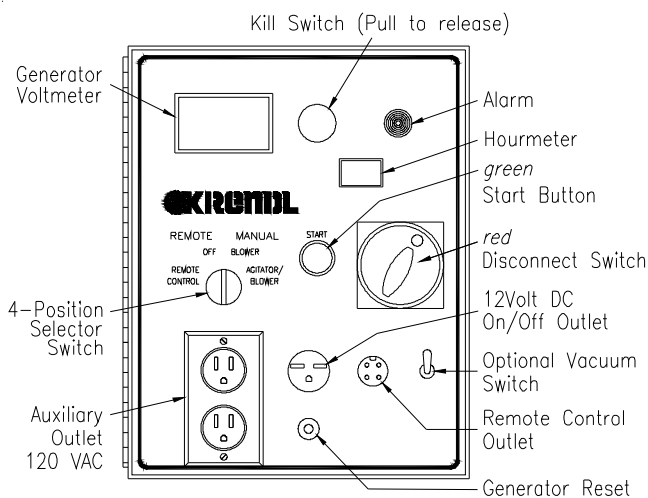

**Main Control Panel (back)  
Illustration 4**

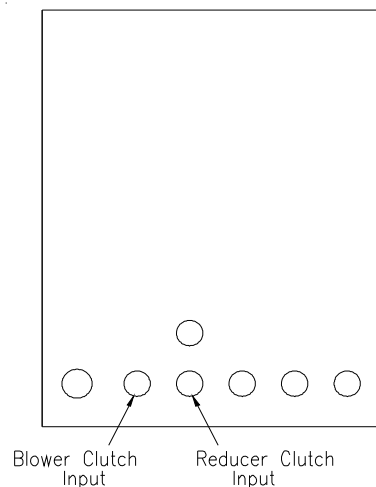

- When operating in **Remote mode**, the 4-Position Selector Switch must be set to **Remote** position. (See illustration 3 on page 11.)
- Remote control hand pendant positions will be selected from the following:

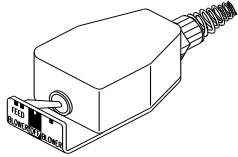

- BLOWER-FEED** - operates both **blower** and **agitator-feed** simultaneously
- OFF** - (middle position) all functions stop
- BLOWER** - operates the **blower** only

- Use the Auxiliary Outlet on the Main Control Panel for supplying **continuous** power (while *red* Main Disconnect Switch is ON) to accessories.

### Stopping Your Machine:

- Switch the Remote Switch to “AIR ONLY” and wait until the hose is clear of all material.
- Turn the Control Switch on the remote control cord to the OFF position.
- Turn the Main Disconnect Switch to the OFF position.
- Disengage the PTO by depressing the cruise control OFF, then depress PTO red rocker switch to OFF position.

---

#### SAFETY NOTE:



DO NOT FILL THE HOPPER TO CAPACITY AT THE END OF THE DAY. THE MATERIAL WILL COMPRESS AND CAN CAUSE MACHINE LOCKUP DURING THE NEXT START-UP.

---

### Mechanical Settings:

The controls of your machine contain the blower and slidegate controls to adjust your machine for each application and type of fiber. (See illustration 5 on page 13.) **Blower control** (air) and **slidegate** (material feed) are adjusted according to:

- TYPE OF MATERIAL: Cellulose and fiberglass have different textures and densities that respond to machine settings.
- HOSE: Corrugations or roughness of interior surface, diameter, length and elevation of hose will also require varying adjustments.
- WEATHER CONDITIONS: Temperature and humidity may require day to day adjustment of machine settings.

### Blower Control and Slidegate General Settings:

Blower control can increase or decrease the amount of air in the system, affecting the velocity (speed) and spread rate (coverage) of fiber. (See illustration 5 on page 13.) The blower control valve is used for controlling air pressure and amount of air flow.

Opening or closing slidegate (material feed) controls the amount of fiber dropping into the airlock which changes the production rate (lbs. per hour). (See illustration 5 on page 13.) For calibration purposes the scale located on the machine indicates how many inches the airlock slidegate is opened.

The blower and slidegate controls **working together** affect the distance fiber can be blown through a hose without plugging. These controls also affect the accurate blowing of fibers for spraying applications.

These settings control the following:

- **Density** of fiber blown in application.
- **Velocity** of material impact when spraying.
- **Dust** on open blow.
- Material **spread rate** or coverage.
- **Production** rate (lbs. per hour blown).

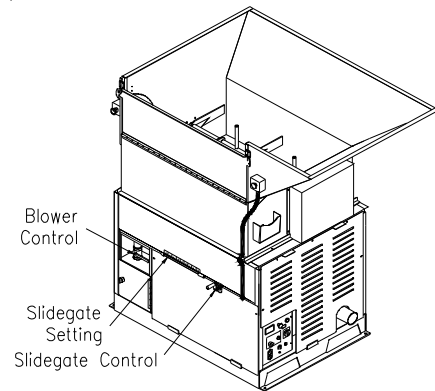

**Illustration 5**

### General Blower Control and Slidegate Settings for Open Blow:

With the **slidegate** closed and blower control valve on low (valve open), turn **agitator-feed and blower on**. Fill hopper with insulation and adjust **blower valve** and **slidegate**. Move controls proportional to each other. (i.e. If **blower valve** is half open, **slidegate** should be half open.) As hose length is increased, air pressure/volume is increased by closing off the **blower valve** while closing the slidegate proportionally. This will increase the distance fiber can be blown through the hose, while decreasing the blowing production rate (lbs. per hour blown). (See illustration 5)

### Shredder Assembly:

This unit is supplied with a shredder assembly; airlock/agitator speeds are preset at the factory. **No** further sprocket setting speeds are needed, as this system will accommodate most fibers and applications. However, the shredder and agitator **direction** can be adjusted as described below.

### Shredder & Agitator Adjustment:

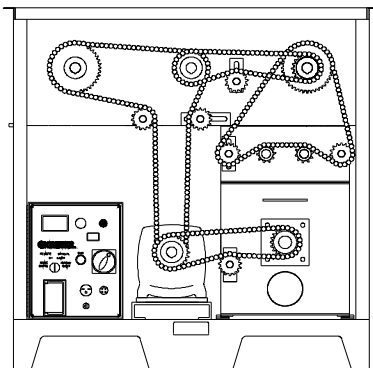

**Illustration 6**

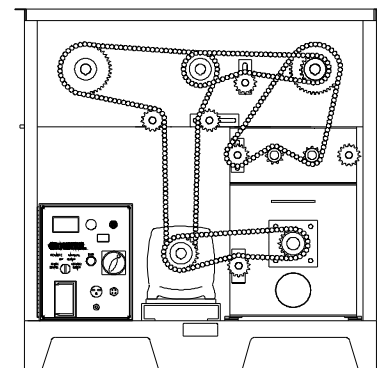

**Illustration 7**

**Unidirectional Rotation** (See illustration 6) is preferred as an all-around setting for a combination of materials and applications. This setting provides the greatest **coverage** and **best control** for internal wetting (stabilized) and open blow applications.

**Center-Down Rotation** (See illustration 7) force feeds the fiber into the airlock at a faster rate. This direction provides the greatest **production** for cellulose fibers in an open attic blow application although coverage may decrease.



**GENERAL MAINTENANCE**

Your Krendl Model #5200-TG-A Machine is designed to be used with minimal maintenance for all its components. The following is only a guide; experience is the best guide for the right maintenance schedule for you.

DESCRIPTION	EACH SHIFT	40 HOURS	200 HOURS	1000 HOURS
CHECK GUARDS	X			
CHECK DRIVE ALIGNMENT & TENSION		X		
VISUALLY INSPECT COUPLING ELEMENTS FOR FATIGUE CRACKS (OVER 1/2")		X		
CLEAN BLOWER AIR FILTER		X		
CHECK BLOWER OIL LEVEL		X		
GREASE PTO SHAFT BEARINGS		X		
GREASE BLOWER BEARINGS			X	
LUBRICATE DRIVE CHAINS WITH A DRY LUBRICANT			X	
GREASE SHREDDER, AIRLOCK, AGITATOR, & JACK SHAFT BEARINGS			X	
CHANGE BLOWER OIL (needs to be changed after first 100 hours of operation and thereafter every 1000 hours)				X

**NOTE:** When further maintenance is needed, please refer back to other manufacturer's manuals for additional assistance!

**SAFETY NOTE****WHEN MAINTENANCE IS TO BE PERFORMED ON THE MACHINE ALWAYS:**

- 1) STOP THE ENGINE COMPLETELY.
- 2) TURN THE IGNITION TO THE "OFF" POSITION AND REMOVE THE KEY.

**RECOMMENDED LUBRICATION**

ALL BEARINGS:	GREASE: TRITON 460 or MOBILITH SHC 460 (NLGI grade #1.5)
DRIVE CHAIN:	DRY LUBRICANT (EG: DRY GRAPHITE)
BLOWER:	OIL: MD ONE (Refer to blower manual) GREASE: TRITON 460 or MOBILITH SHC 460 (NLGI grade #1.5)
AIRLOCK REDUCER:	OIL: KLUBERSYNTH UH1 6-460
PTO BEARINGS:	GREASE: TRITON 460 or MOBILITH SHC 460 (NLGI grade #1.5)

**Bearing Grease Zerks**

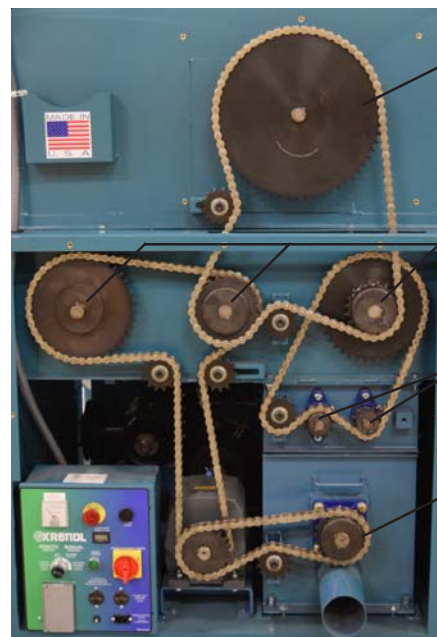
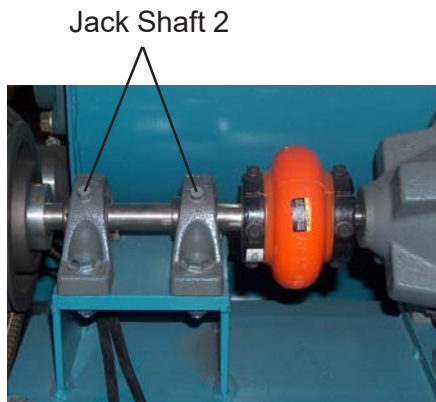
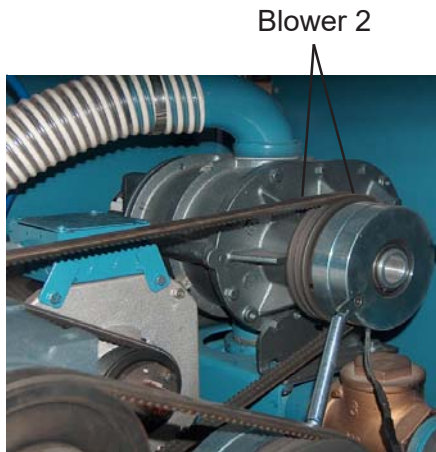

Hopper Fittings  
(1 per side)

Agitator Fittings  
(3 per side)

Shredder  
(2 per side)

Airlock  
(1 per side)

**Airlock: (Seal Replacement)**

The purpose of the airlock seal is to trap air and fiber until it rotates 180° to the 6:00 o'clock position. At this point, fiber is pushed by air from the blower, out of the chamber. Worn or damaged seals allow air and fiber to escape back into hopper, thus reducing production and coverage. When it is necessary to replace seals, follow these directions:

Remove chain and air hoses from both input and output of airlock. Using a 5/8" socket, remove hold down bolts from airlock. Lower the front of the airlock down by loosening the jamb nuts and turning the liftbolts counter clockwise. Slide the airlock out of the machine. (See illustration 8) Airlock rotor plates that are damaged (bent) will need replaced. (Refer to Rotor Plate Replacement below.) Take out rubber seal by removing seven plate fastening bolts and nuts and top plate. The base plate will remain attached to airlock shaft. To install a new seal, reverse procedure. Seal should be inserted tight against the back base plate, pressing the lower tabs of the seal down under the adjacent seal with a flat blade screwdriver. Make sure all bolt holes are aligned while each side of seal is equally pressed against the end plates, before tightening bolts. Seal should be bent forwards for **counter clockwise** rotation. (See illustration 10)

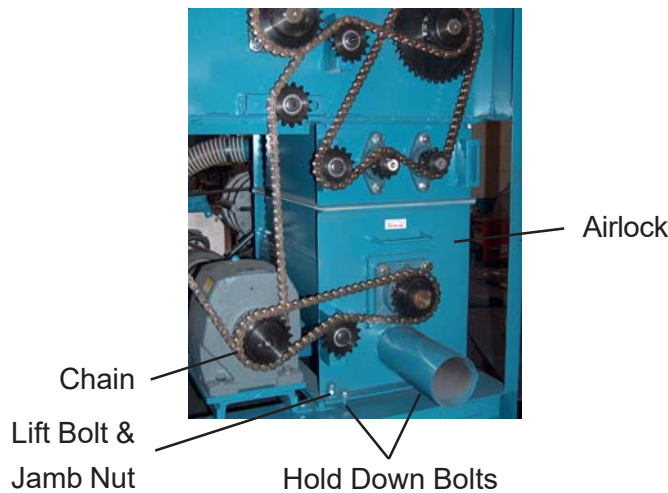

**Illustration 8**

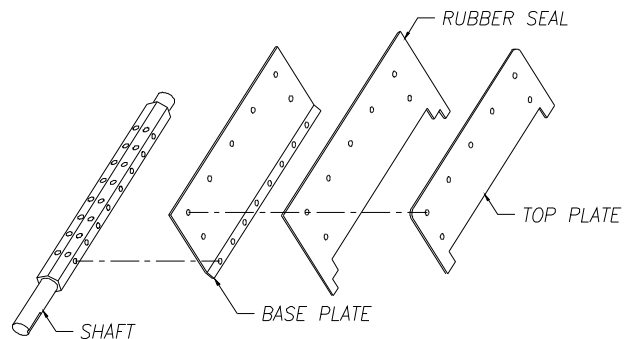

**Illustration 9**

**Base Plate Replacement:**

1. Remove damaged baseplate assembly from shaft using ratchet drive wrench with extension and 9/16" socket.
2. Check seal for wear and damage. (Installing seal and top plate on the bench is quick and easy). Remove bolts from plate assembly and replace with new seal. Make sure seal and top plate are assembled on **correct** side of base plate before assembling in airlock. Seal should press backward towards top plate when installed correctly into airlock chamber. (Illustration 10)
3. Install the rotor plate assembly into the airlock. The airlock runs **counter clockwise** viewing it from the sprocket drive shaft. (Illustration 10) Align the base plate with holes on airlock shaft using a tapered punch.

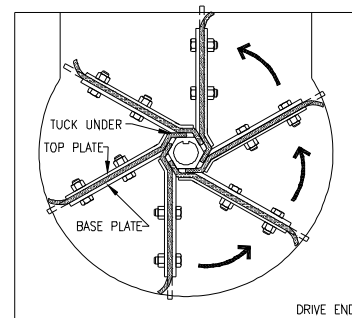

**Illustration 10**

**(Note: Entire rotor plate assembly may be removed and replaced. This procedure maybe easier than replacing just the seals.)**



**Caution:** Do not mount rotor plate backwards. If installed improperly, damage to seals will result and put undue stress on agitator motor. This causes overheating and poor production. Seal should be bent forward to allow for a **counter clockwise** rotation of rotor.

5. As rotor plate is installed, press bottom tab of seal under adjacent seal with flat blade screwdriver. (See illustration 10 on page 16)

### **Chain:** (Adjustment) (#60 Nickel Plated)

A smooth operating chain drive should have a slight sag on the idler side of the chain. New chains should be installed under slight tension as they will elongate a small amount due to seating of pins and bushings during the first few days of operation. Chain should be kept in good condition by proper lubrication (use dry film lubricant Dow 321) and occasional cleaning. Soaking chain in container of 10 weight oil will provide for internal lubrication of pins and bushings. However, excess oil must be drained and wiped away as excessive lubrication will cause fiber accumulation on chain. Worn out chain should be replaced. When chain is replaced, worn sprockets should also be replaced, preventing further damage to new chain.

### **Sprockets:**

**Check Sprockets For Wear.** Misalignment and/or loose sprockets and improper chain tension causes the premature wear of chain and sprockets. All sprockets, except speed reducer and idler sprockets, have been secured with a medium grade Loctite (general purpose thread locker), to prevent gradual movement. The set screws and key are also inserted with a medium grade Loctite. If sprocket is difficult to remove, it may be heated with a propane torch to loosen.



**Caution:** Do not overheat sprocket or damage to bearing will result. A pulley or bearing puller can then be used to remove the sprocket and key. Replace new sprocket on shaft with key and medium grade Loctite applied to shaft. Align sprocket with corresponding sprocket, using a straightedge placed along face of teeth and tighten set screws.

### **Bearings:**

Agitator Bearings in hopper are double-sealed, self aligning ball bearings. They have grease fittings and should be periodically lubricated. At least every 3 months. If bearings produce noise or heat (*too-hot-to-touch*), the bearings should be replaced.

### **Agitator Bearing Replacement:**

Spray area with rust penetrant (WD-40). Remove sprocket (See SPROCKET section above). Remove the four bolts from bearing flange. Loosen set screws on bearing hub at each end of agitator shaft. Since all set screws are installed with a medium grade Loctite, a propane torch may be used to assist in removing them. Do not overheat unit, causing shaft to expand. Using a rubber mallet, drive agitator shaft an inch in one direction, creating a space between hopper and bearing unit. A bearing puller can then be used to remove the bearing. Eliminate any metal burrs from shaft with file and install new bearings with felt seals. Use a medium grade Loctite on set screws before securing bearing to shaft. (Check shaft diameter before ordering bearings)

## ELECTRICAL SYSTEM

**ELECTRICAL DIAGRAM:** Periodically, disconnect machine from power source and check all electrical connections and components for broken or loose wires, loose screws or fasteners. Machine Vibration can cause fasteners to loosen.

### MODEL #5200-TG-A 12 V.D.C. with 120V Generator

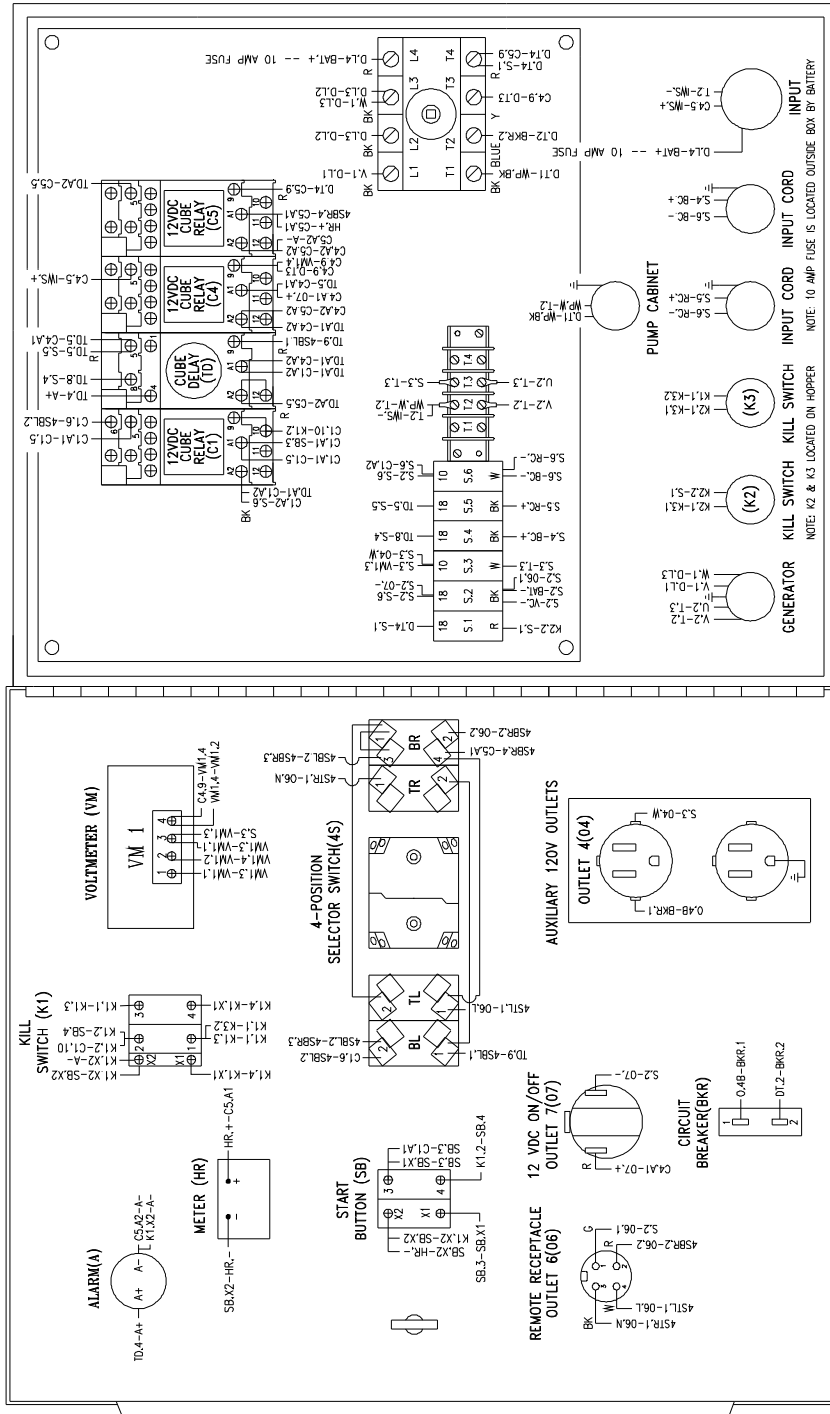

**WIRE COLOR CODE**

- G = GREEN - Earth Ground
- W = WHITE - Common (120 volt)
- BK = BLACK - Negative (12 volt)
- R = RED - Hot (12 volt)
- BLUE = BLUE - Hot (120 volt)

**4-POSITION SELECTOR SWITCH(4S)  
CONTACT ACTION**

CONTACT ACTION	BOTTOM LEFT	TOP LEFT	BOTTOM RIGHT	TOP RIGHT
REMOTE	+	+	+	+
OFF	+	+	+	+
BLOWER	+	+	+	+
BLOWER/ AGITATOR	+	+	+	+

Illustration 11

**ELECTRICAL DIAGRAM:** Periodically, disconnect machine from power source and check all electrical connections and components for broken or loose wires, loose screws or fasteners. Machine Vibration can cause fasteners to loosen.

## MODEL #5200-TG-A 12 V.D.C. (Optional Vacuum System)

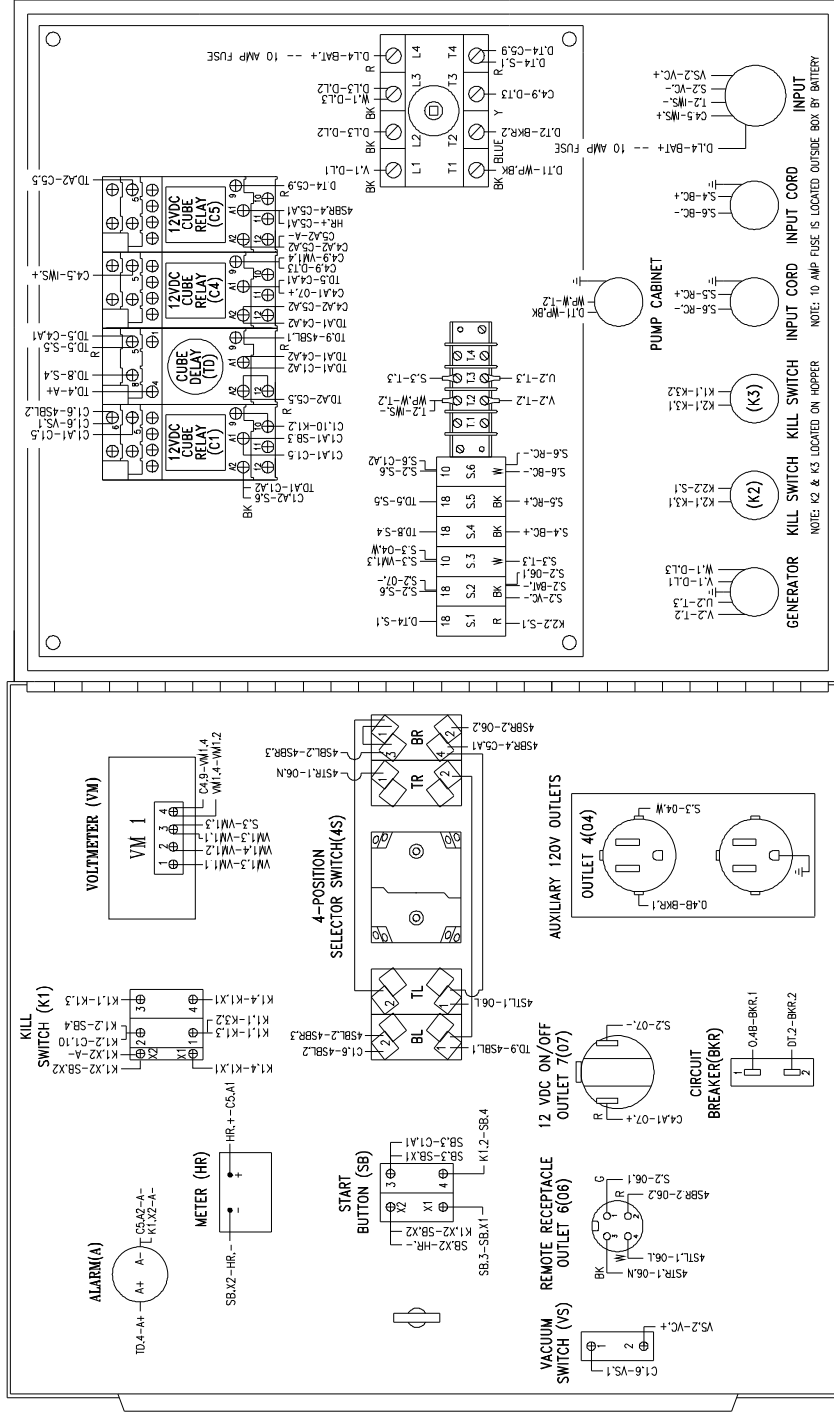

4-POSITION SELECTOR SWITCH(4S)  
CONTACT ACTION

REMOTE	+	+	+	+	+	+	+
OFF	+	+	+	+	+	+	+
BLOWER	+	+	+	+	+	+	+
BLOWER/AGITATOR	+	+	+	+	+	+	+
	BOTTOM	TOP	TOP	TOP	TOP	BOTTOM	BOTTOM
	LEFT	RIGHT	RIGHT	RIGHT	RIGHT	RIGHT	RIGHT

**WIRE COLOR CODE**

G	=	GREEN	-	Earth Ground
W	=	WHITE	-	Common (120 volt)
BK	=	BLACK	-	Negative (12 volt)
R	=	RED	-	Hot (12 volt)
BLUE	=	BLUE	-	Hot (120 volt)

Illustration 12

**ELECTRICAL DIAGRAM:** Periodically, disconnect machine from power source and check all electrical connections and components for broken or loose wires, loose screws or fasteners. Machine Vibration can cause fasteners to loosen.

**MODEL #5200-TG-A  
12 V.D.C. with No Generator**

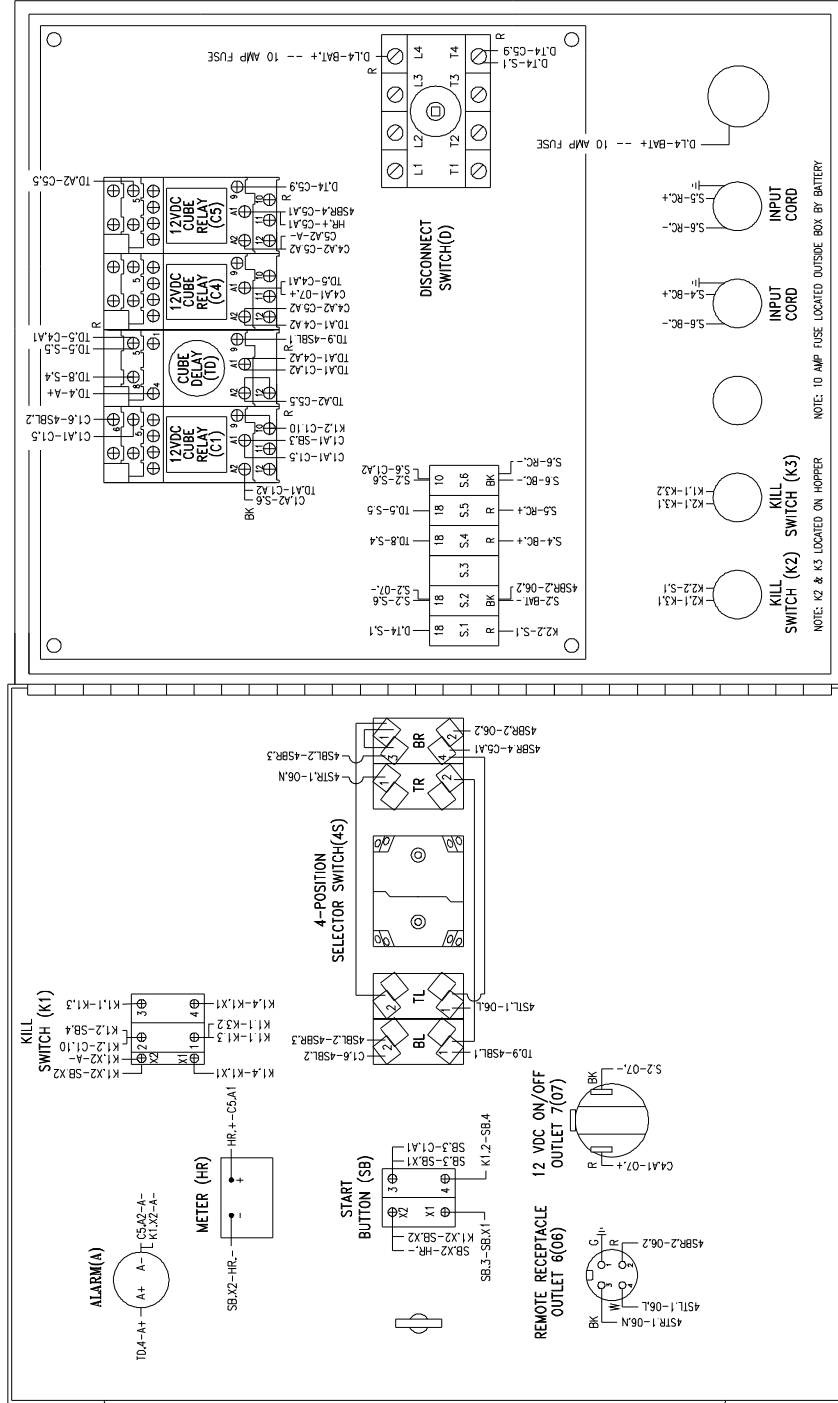

**4-POSITION SELECTOR SWITCH(AS)  
CONTACT ACTION**

CONTACT ACTION	BOTTOM	TOP	LEFT	RIGHT
REMOTE	+	+	+	+
OFF	+	+	+	+
BLOWER	+	+	+	+
BLOWER/ AGITATOR	+	+	+	+

**Illustration 13**

**WIRE COLOR CODE**

G	= GREEN	- Earth Ground
W	= WHITE	- Common (120 volt)
BK	= BLACK	- Negative (12 volt)
R	= RED	- Hot (120 volt)
BLUE	= BLUE	- Hot (120 volt)

**TROUBLESHOOTING****WARRANTY**

This unit is backed by a warranty for manufacturer's defects. If your machine needs service during the warranty time period, call your supplier immediately. DO NOT attempt to service the machine, as this voids the warranty!

**IMPORTANT**

At any signs of trouble with your machine, stop immediately, disconnect power and call your supplier. Refer to the GENERAL MAINTENANCE section of this manual for further details. Always disconnect the electrical power before making any inspections or repairs.

**TROUBLESHOOTING****PROBLEM**

- 1.) PTO will not engage
- 2.) Engine starts or PTO engages but there are no other machine functions - no electrical power to the front panel
- 3.) Engine starts or PTO engages - but the blower will not operate
- 4.) Insufficient air - clutch is operating

**CORRECTIVE ACTION**

- A. See truck manufacturer's PTO accessory manual.
- A. Check for loose or damaged wires, ground shorts. which may be caused from machine vibration.
- B. Turn off all power to machine before opening the panel box.
- A. Check to see if the blower clutch is operating
- B. Check clutch electrical connections.
- C. Check belts, adjust or replace as required.
- D. Check battery, clutch will not cycle or will slip if battery is not fully charged.
- E. Check that blower can be turned by hand. If not, blower may be tied up.
- F. Weak/Worn clutch- replace or rebuild as required.
- A. Check that the blower control valve isn't fully open. Close or adjust the handle control as needed. You should be able to get over 4 p.s.i. of air on gauge. See illustration 14.
- B. Check that the blower relief valve is not stuck open. See illustration 15 on page 22.
- C. Check if blower air filter and intake hose is clogged. See illustration 14.
- D. Check airstream and bypass air hose connections, clamps, etc.
- E. Check that the one way air check valve isn't stuck closed. See illustration 15 on page 22.

**Illustration 14**



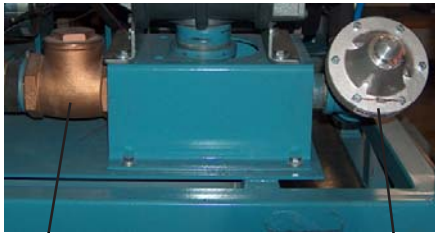

Check Valve

Relief Valve

**Illustration 15**

5.) No material flow - clutch is operating

- F. Check belts, adjust /replace as required and check for missing keys under drive pulleys.
- G. Insulation hose plugged. Make sure the air bypass valve is completely closed, then switch machine to blower only to blow out the hose. If problems still occur, try hitting the hose where it is plugged to release the material.
- H. If the airlock seals and/or airlock components are worn or damaged, replace all the parts as needed.

- A. Check material level in main hopper.
- B. If the material slide gate is closed or adjusted in too far for material feed rate, open the slidegate.
- C. Check the belts coming from the main drive shaft pulley to the reducer shaft drive pulley and blower shaft drive pulley. Adjust or replace belts as required. Check for missing keys under the drive pulleys.
- D. Check chains, adjust or replace as required. Check for missing keys under drive sprockets.
- E. Insulation hose plugged. Make sure the air bypass valve is completely closed, then switch machine to blower only to blow out the hose. If problems still occur, try hitting the hose where it is plugged to release the material.

## SPARE PARTS LIST

The following is a recommended spare parts list. To keep your machine up and running, these are the parts we suggest you keep on hand for your Model #5200-TG-A Krendl Machine.

PART #	DESCRIPTION	QUANTITY
250503-8	AGITATOR BEARINGS	8
250503-7	AGITATOR BEARING FELT SEALS	8
8036-2	SHREDDER BEARINGS	4
517-7	SHREDDER BEARING FELT SEALS	4
8065-2	AIRLOCK BEARINGS	2
8065-3	AIRLOCK BEARING FELT SEALS	2
5200T13	JACK SHAFT BEARINGS	2
5200T16	V-BELT PTO SHAFT TO GENERATOR	1
5200T17	V-BELT PTO SHAFT TO JACKSHAFT	1
5200T18	V-BELT JACKSHAFT TO BLOWER	1
5200-9M-2PLYF	AIRLOCK SEALS	6
ML-60NP	#60 MASTER LINK	6
5200TG-MK	5200-TG-A / 6000T MAINTENANCE KIT	1

**PARTS LIST**

**#5200-TG-A Exploded Parts View**

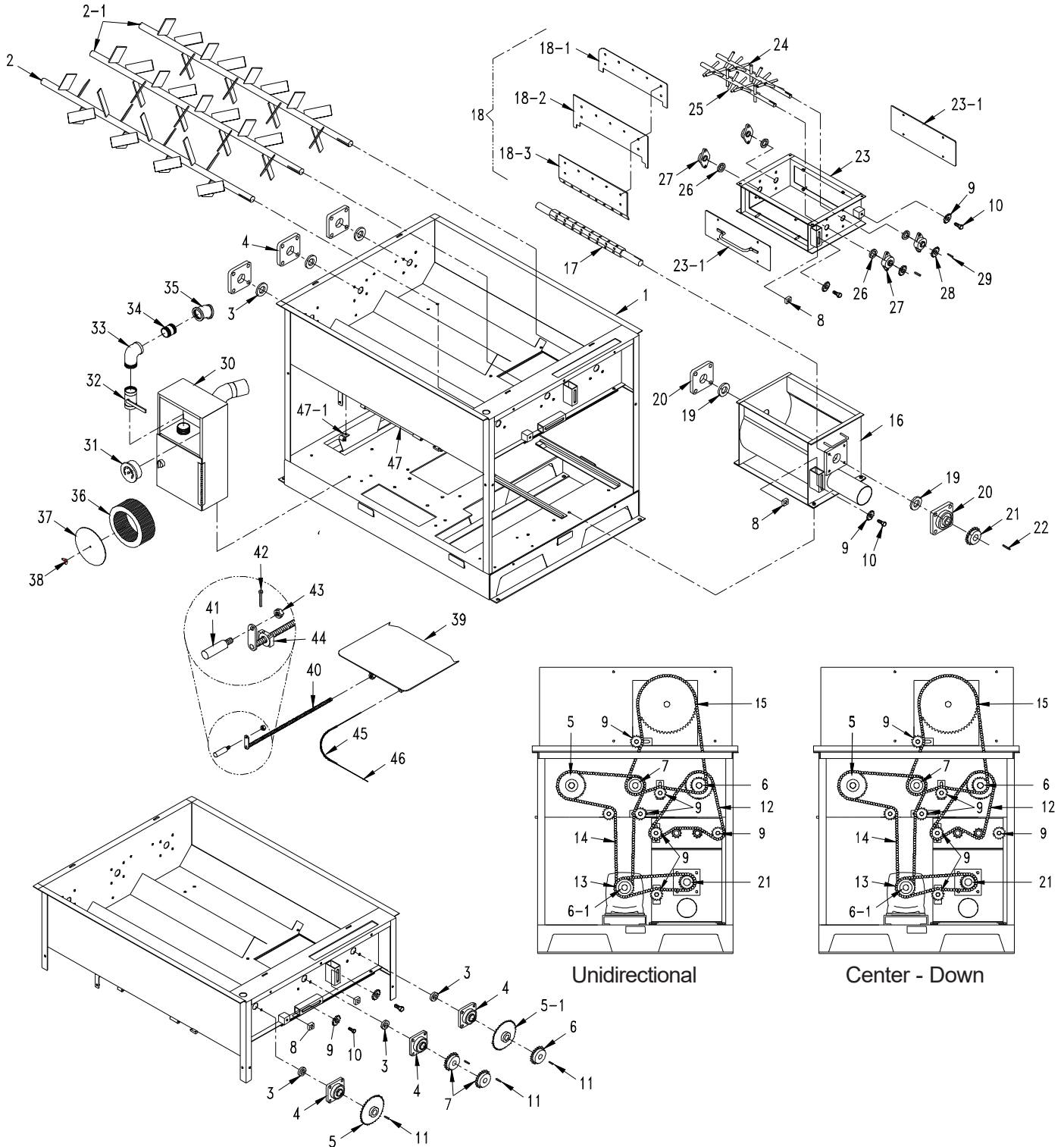

**#5200-TG-A Exploded Parts View**

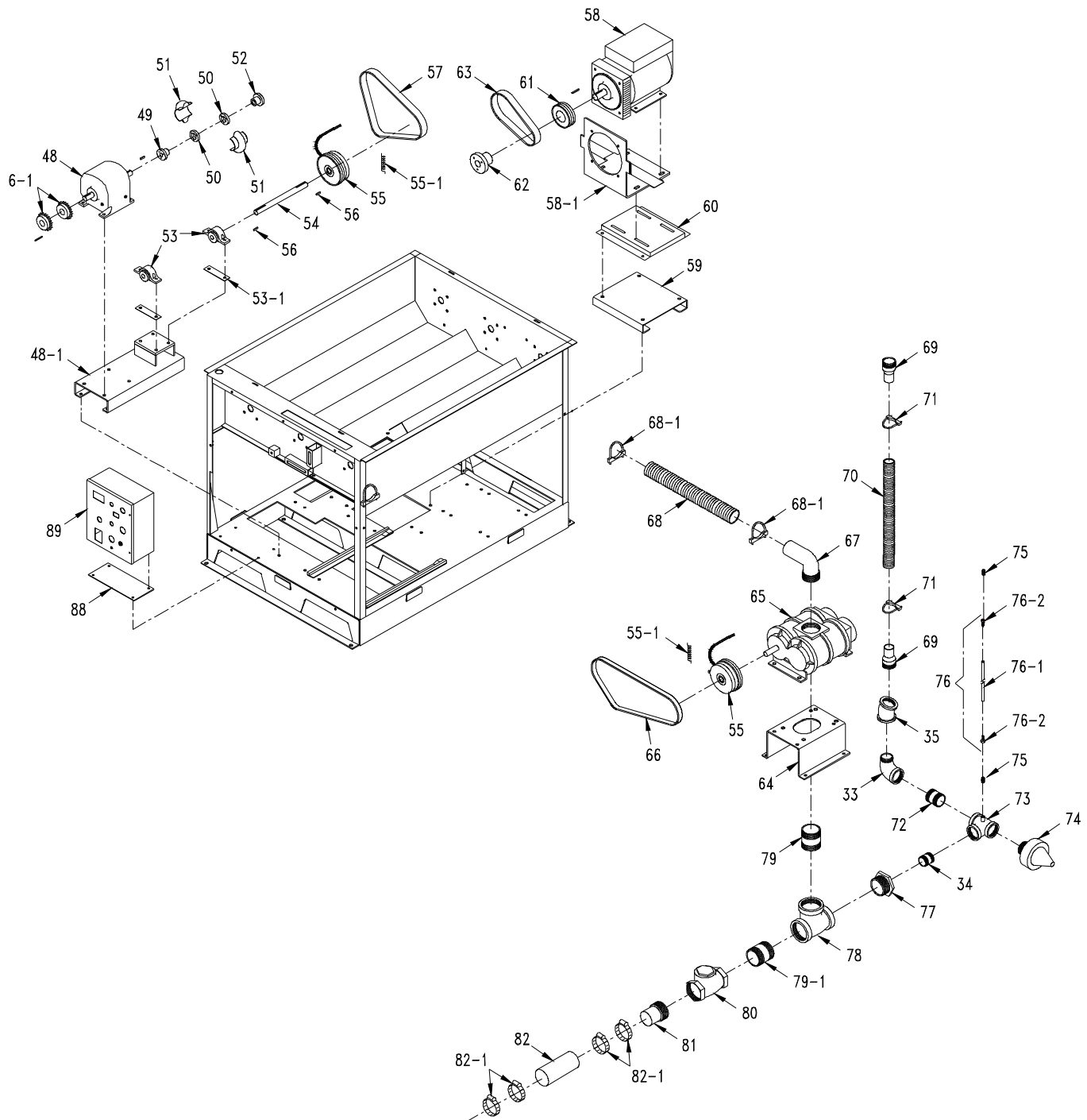

**#5200-TG-A Exploded Parts View**

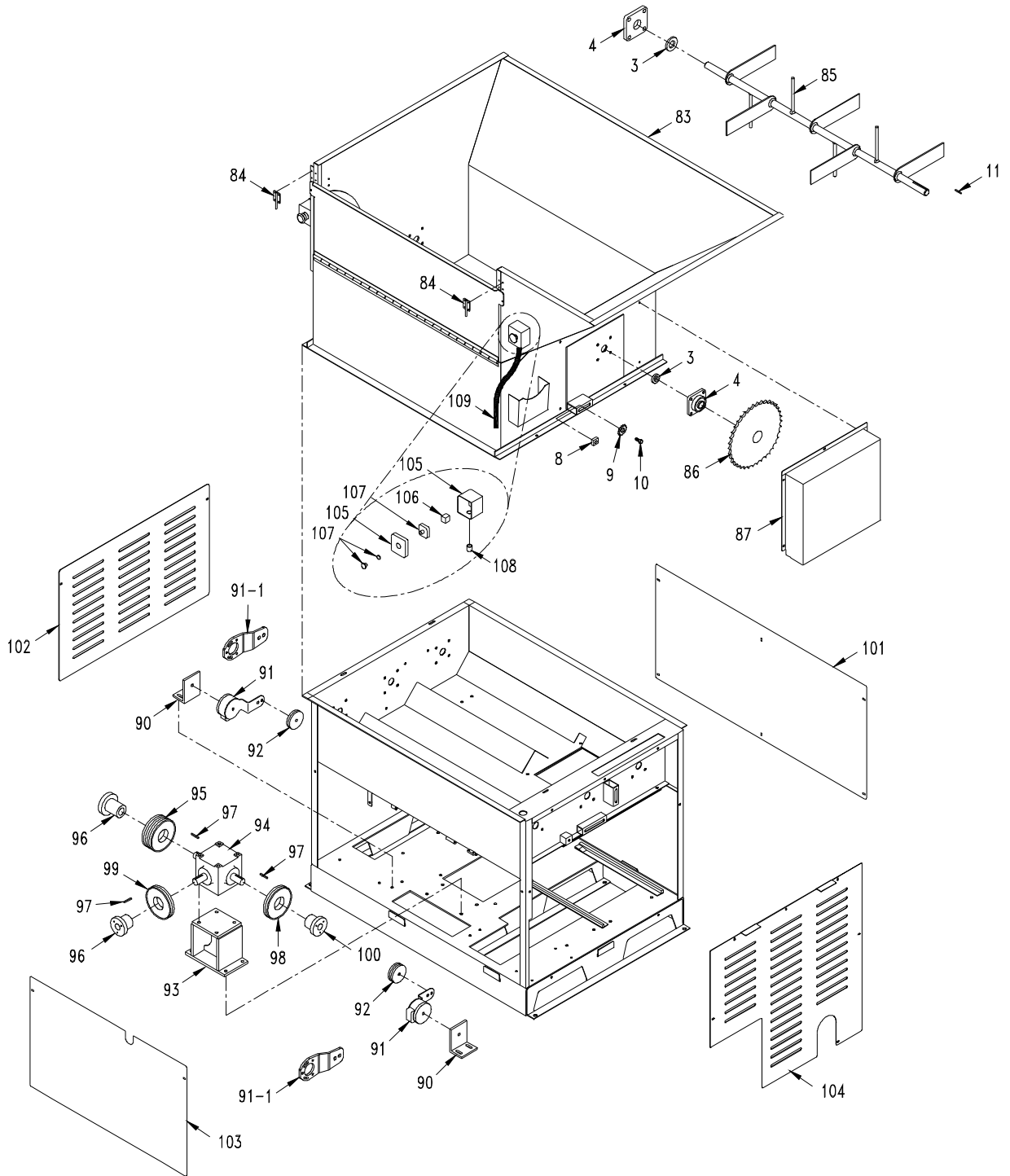

**#5200-TG-A Exploded Parts List**

<b>Item#</b>	<b>Part#</b>	<b>Description</b>
1	5200T1	Base, (Upper&Lower Portion)
2	4000-15	Agitator, Hopper, 16 Tine
2-1	4000-29	Agitator, Middle & Shredder, 17 Tine (2)
3	250503-7	Seal, Felt, 1 1/4" (8)
4	250503-8	Bearing, Flange, 4-Bolt, 1 1/4" (8)
5	S-H60B40F-1.25	Sprocket, #60 40T x 1 1/4"
5-1	5200-121	Sprocket, #60 40T Turned Down
6	S-H60B20F-1.25	Sprocket, #60 20T x 1 1/4"
6-1	5200-122	Sprocket, #60 20T x 20T x 1 1/4"
7	S-H60B25F-1.25	Sprocket, #60 25T x 1 1/4" (2)
8	40052	Nut, 1" x 1" x 1/2" (Plated) (5)
9	60BB13H	Sprocket #60, Idler, 13HT x 5/8" (7)
10	FSB120	5/8" X 3/4" Shoulder Bolt (7)
11	561Z	1/4" x 1/4" x 1" Key (4)
12	60NP-51	Chain, #60 x 51" Long (Center Down)
12	60NP-55	Chain, #60 x 55" Long (Unidirectional)
13	60NP-40.5	Chain, #60 x 40 1/2" Long
14	60NP-90	Chain, #60 x 90" Long
15	60NP-84	Chain, #60 x 84" Long
16	5200T2-R1	Chamber, Airlock, 5200
17	5200-6	Shaft, Airlock, 5200
18	5200-9-ASSY	Seal Assy, 5200, 18" (2 PLY/FAB) (6)
18-1	5200-7	Plate, Top, Airlock (6)
18-2	5200-9M-2PLYF	Seal, Airlock (6)
18-3	5200-8	Plate, Bottom, Airlock (6)
19	8065-3	Felt Seal, 1 1/2" (2)
20	8065-2	Bearing, 4-Bolt, 1 1/2" (2)
21	S-H60BS20-1.5	Sprocket, #60 20T x 1 1/2"
22	556	3/8" Square Stock, 1 1/4" Long
23	5200-10-R1	Shredder Box
23-1	5200-129	Access Cover, Shredder Box (2)
24	5200-11-A	Shredder Agt., Short (18 Tine)
25	5200-11-B	Shredder Agt., Long (20 Tine)
26	517-7	Seal, Felt Airlock 1" Bore (4)
27	8036-2	Bearing, 2-Bolt, 1" (4)
28	S-H60B11F-1	Sprocket, #60, 11T x 1" (2)
29	448Z	Key, 3/16" x 3/16" x 1" (2)
30	5200T6	Box, Filter
31	5200-59	Gauge, Pressure, 0-10 PSI
32	8051	Ball Valve, 2"
33	5200-64	Elbow, 2", 90 Degree Street (2)
34	5200T19	Nipple, 2" Pipe, 5" Long (2)
35	250340-2	Elbow, 2", 45 Degree, Black Pipe (2)
36	81-1063	Filter, F/250300-2-R1 (Blue)

**#5200-TG-A Exploded Parts List**

<b>Item#</b>	<b>Part#</b>	<b>Description</b>
37	5200-63	Cover, Filter
38	FN014	5/16-18 Locknut-Crimped
39	5200-45	Slidegate, 5200
40	5200-46	Crankrod w/Handle Bracket
41	5200-60	Handle
42	FSB078	Pin, Cotter, 1/8" x 1"
43	FN015	N 3/8-16 Lock Nut-Crimped
44	5200-58	Support, Crankrod
45	5200-74	Cover, Slidegate Cable, 18 1/4"
46	5200-67	Cable, Indicator, Slidegate, 33"
47	5200-68	Cover, Slidegate Indicator
47-1	5200-69	Mount, Indicator Cable
48	5200-98	Reducer, 5200
48-1	5200T5	Reducer Mounting Plate
49	5200-102	Bushing, JA 3/4"
50	5200-87	Hub, F/E4 Element (2)
51	5200-86	Element, Coupling, E4 (2)
52	5200T11	Bushing, JA 7/8"
53	5200T13	Bearing, 7/8" P.B. (2)
53-1	5200-51	Shim, Bearing (2)
54	5200T14	Jack Shaft, Reducer, 13" Long
55	5200-101	Clutch, Shaft Mount, 2 Groove (2)
55-1	5200-114	Spring, 9/16 x 6 x .072 (2)
56	109080	Key, 1/4" x 1/4" x 2 1/8" Long (2)
57	5200T17	Belt, 2/3VX400
58	5200-20C	Generator, 14.4 KVA
58-1	5200-128-R1	Generator Bracket
59	5200T23	Spacer, Generator
60	2100-8	Mount, Motor
61	2/3V365SH	Sheave 2 Groove
62	5200-20C-1	Bushing, 28MM Taper Lock
63	5200T16	Belt, 2/3VX355
64	4200-4	Blower Mount
65	250300-1	Blower, Rotary, 10HP, #4007
66	5200T65	Belt, 2/3VX650
67	5200-65	Elbow, Inlet
68	RM-OTH097-MI	Pipe, Exhaust, 3" Flex, 30" Long
68-1	5200-106-3	Clamp, Muffler, 3" (2)
69	5200-81	Adapter, 2" Barb (2)
70	RM-OTH103-MI	Pipe, Exhaust, 2" Flex, 36" Long
71	5200-106	Clamp, Muffler, 2" (2)
72	250338-3	2" Pipe Nipple, 3" Long
73	5200T24	Tee, 2" w/1/4" Coupler

**#5200-TG-A Exploded Parts List**

<b>Item#</b>	<b>Part#</b>	<b>Description</b>
74	4200-12	Relief Valve, Pressure, 6 PSI
75	IWS-32	Male Connector (2)
76	IWS-25A	Water Line, 1/4" x 6' w/swivel
76-1	IWS-H-1/4	1/4" Hose
76-2	IWS-29	Swivel, SAE 37 (2)
77	5200T15	Reducer, Bushing, 3" x 2" Black Pipe
78	8306SB-5	Tee, 3"
79	5200T20	3" Pipe Nipple, 3" Long
79-1	5200T50	Nipple, 3" x 5"
80	250539	Check Valve, 3"
81	5200-62	Adapter, 2" Long, Male
82	RM-OTH095-MI	3" Heater Hose, 5" Long
82-1	339A	Clamp, Hose, 3" (4)
83	5200T41	Hopper Extension, 5200-TG
84	270700-2-13	Barrel Slide (2)
85	5200-131-R2	Hopper Agitator (Replaces 5200-131-R1)
86	S-H60B60F-1-1/4	Sprocket, #60 60T x 1 1/4"
87	5200-133	Guard, Chain, Hopper Extension
88	5200T40	Spacer, 2-Ply Rubber, 5" x 11 1/2"
89	5200T27-KT-ASSY	Panel Box Assy (w/Generator)
89	5200T27-KT-NGASSY	Panel Box Assy (w/ No Generator)
90	5200-105-R2	Idler Bracket (2)
91	5200-22	Tensioner, H.D., Rotary (2)
91-1	GV230-33	Tensioner Bracket (2)
92	5200-96	Idler, 2GR3V3.35 (2)
93	5200T4	Mount, Gear Box
94	5200T3	Gear Box
95	5200-27	Pulley, 5GR3V6.90
96	5200T12	Bushing, SK 1 1/4 (2)
97	150311Z	Key, 1/4" x 1/4" x 1 3/4" (3)
98	5200T29	Pulley, 2GR3V5.60 SH
99	5200T32	Pulley, 2GR5V7.1 SK
100	5200T8	Bushing, SH 1 1/4
101	5200-49-R1	Guard, Side (Blower Side)
102	5200T26	Guard, Side (Generator Side)
103	5200T25	Guard, Side (Crankrod Side)
104	5200T21	Guard, Chain
105	8076	Enclosure (2)
106	8075-1	Contact Block (2)
107	508-2	Killswitch (2)
108	543-M-18	Connector, Conduit, 1/2" Straight (2)
109	543-M-75	Conduit, Flexible 1/2"
110	HL-60NP	Link, Half, #60 (Not Shown)
111	ML-60NP	Link, Master, #60 (6) (Not Shown)

**#5200-TG-A Exploded Parts List  
Optional Vacuum System**

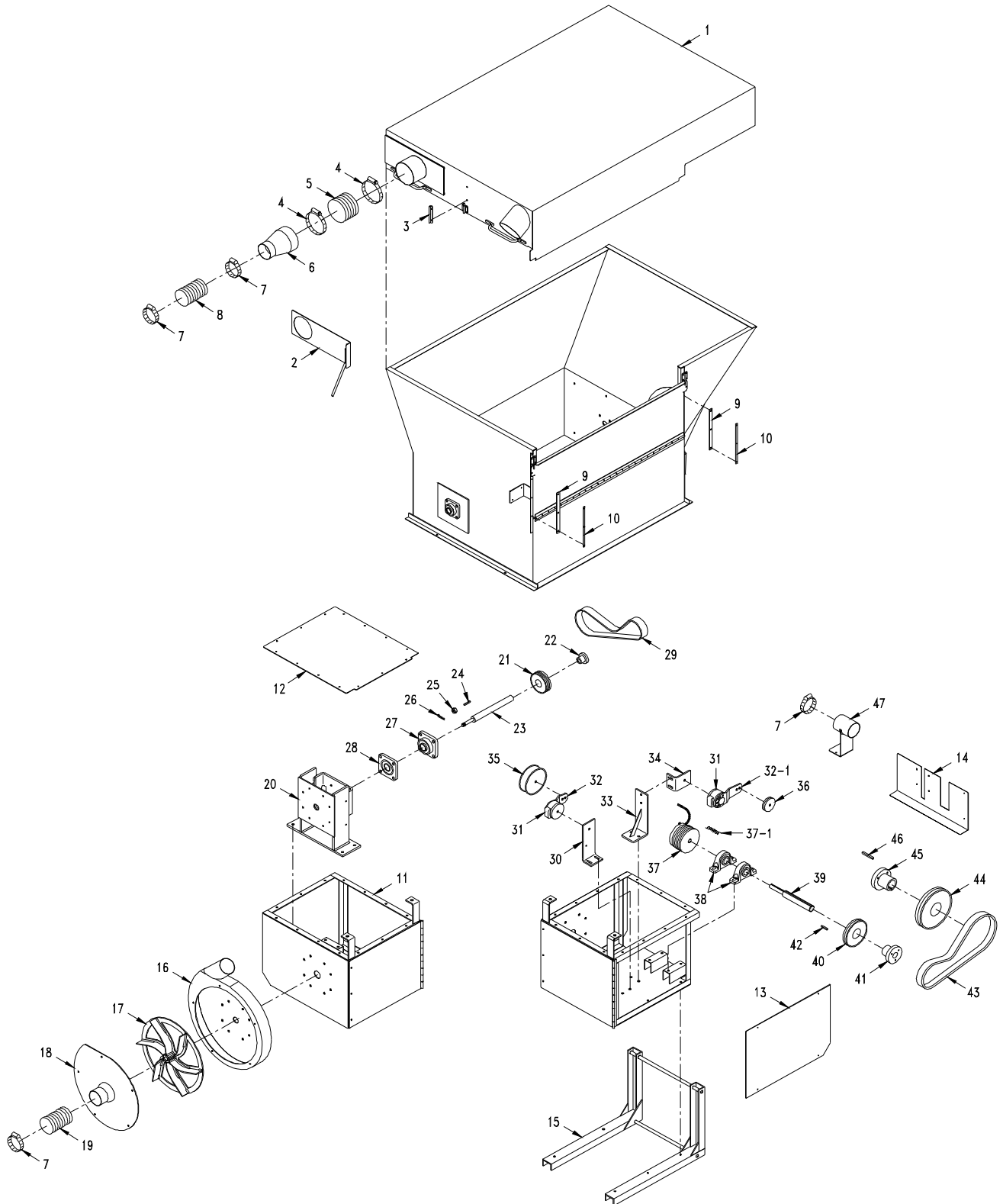



**#5200-TG-A Exploded Parts List  
Optional Vacuum System**

<b>Item#</b>	<b>Part#</b>	<b>Description</b>
1	5200T42	Recycle Hood
2	5200T43	Slidegate, Recycle Hood
3	5200RH-3	Slidegate Stop
4	341	Clamp, Hose, 6" (2)
5	H430	Hose, 6" Flexhaust, 4" Long
6	371P	Reducer, 6" to 4" Connector
7	340	Clamp, Hose, 4" (4)
8	H420	Hose, 4" Spiralite, 8 Ft. Long
9	5200RH-5	Strip, Rubber, 7/8" x 12 5/8" (2)
10	5200RH-4	Strip, Cover, 1/2" x 12 1/2" (2)
11	5200T45	Vacuum Box
12	5200T47	Top Guard, Vacuum Box
13	5200T52	Side Guard, Vacuum Box
14	5200T58	Back Guard, Vacuum Box
15	5200T44	Mounting Frame, Vacuum Box
16	5200T55-R1	Chamber, Vacuum, 20"
17	5200T59	Fan, Vacuum, 20"
18	5200T56-R1	Cover Plate, Vacuum, 20"
19	H423	Hose, 4" Tiger Flex, 12 Ft. Long
20	5200T46	Stand, Vacuum
21	5200T62	Pulley, 4 1/8" Dia., 4 Groove
22	5200T64	Bushing, 1 7/16"
23	260503	Shaft, Fan, 14"
24	109080	Key, 1/4" x 1/4" x 2 1/8"
25	FN034	Slotted Nut, 1"-14
26	150310	Pin, Cotter, 1/8" x 2"
27	260385	Bearing, 4 Bolt Housing (Fixed)
28	260385-1	Bearing, 4 Bolt Housing (Expansion)
29	5200T63	Belt, 4/3V500
30	28-7	Tensioner Bracket (Short)
31	5200-22	Tensioner, H.D., Rotary (2)
32	GV230-33	Tensioner Arm (Short)
32-1	6000T31	Tensioner Arm (Long)
33	5200T51	Tensioner Bracket (Tall)
34	5200-105-R1	Bracket, Pulley Mounting
35	5200T72	Idler, 6.28" O.D. x 1/2" Bore
36	GV230-31	Idler, Flat Belt w/Adapter
37	5200-99T	Clutch, Shaft Mount, 5 Groove
37-1	5200-114	Spring
38	5200T60	Bearing, 1 1/2" P.B. (2)
39	5200T54-R2	Shaft, Jack, 1 1/2" Dia., 13 1/2" Long
40	5200T71	Sheave, 2/5V0440SH
41	5200T61	Bushing, 1 1/2"
42	562Z	Key, 1/4" x 1/4" x 1 1/4"
43	5200T73	Belt, 2V/5V530
44	5200T31	Pulley, 2GR5V10.3SK
45	5200T33	Bushing SK 2
46	KS353-13	Key, 3/8" x 3/8" x 2 5/8"
47	5200-145	Bracket, Mounting, Vacuum Hose

### #5200-TG-A Exploded Parts List Optional Hose Reel

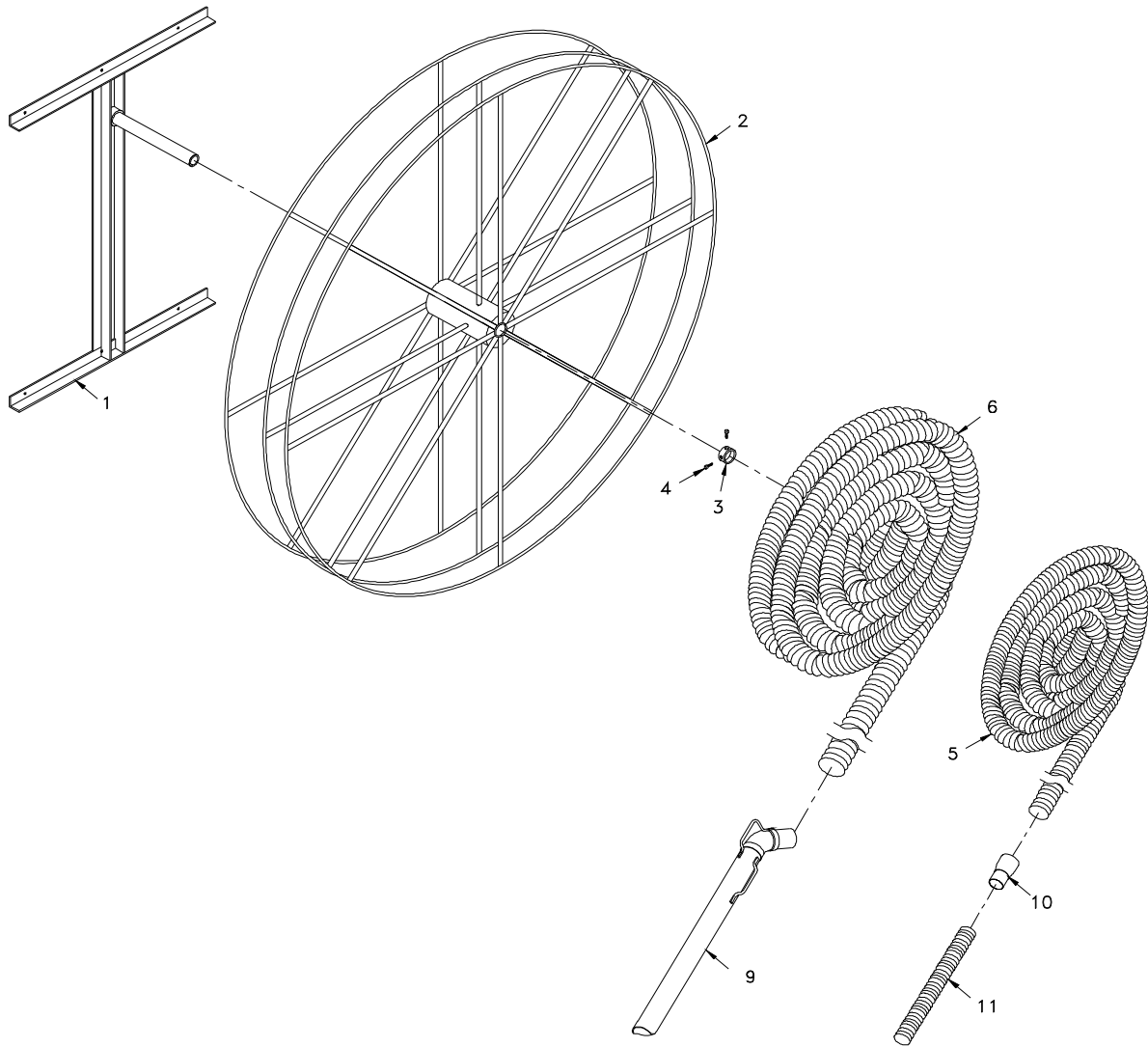

Item#	Part#	Description
1	KS337	Wall Mount, Hose Reel
2	KS333	Reel, Hose, 90" x 12 1/2" Wide
3	328-C-M-H	Collar, Hose Reel
4	FSB036	5/16 -18 x 5/8" Hex (2)
5	H319	Hose, Flexhaust, 3" x 50' (3)
6	H400	Hose, Smooth Bore, 4" x 50' (3)
7	380	Tube, Connector, 3" x 5" (2) (Not Shown)
8	381	Tube, Connector, 4" x 5" (2) (Not Shown)
9	250600-B	Wand, Vacuum, PVC, 4" x 4'
10	359	Reducer Tube, 3" to 2 1/2"
11	H419	Hose, Vaccuflex, 12 1/2'

## 12 V.D.C Electrical w/120V Generator Exploded Parts View

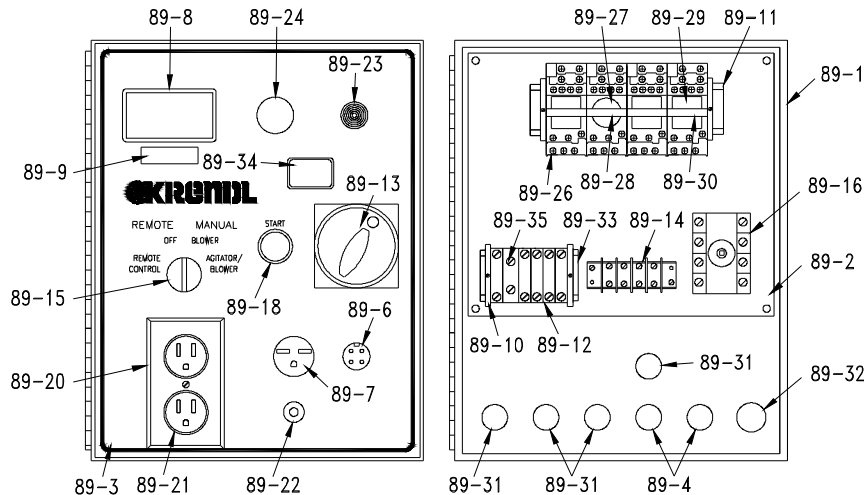

### 12 V.D.C.

Item #	Part #	Description
89-1	5200T39-R1	Box, Electrical
89-2	1563	Plate, Backing, 9" x 11 1/8"
89-3	KMC-236-R4	Decal, Electrical Box
89-4	391N-A-2	Connector, Cord, Liquid Tite, 1/2" White (2)
89-5	391N-A-3	Locknut, Steel, Conduit, 1/2" (2) (not shown)
89-6	491	Connector, 4 Pin Female (remote)
89-7	132-B	Receptacle, NEMA# 6-15R
89-8	543-M-83	Voltmeter, Digital 120V
89-9	KMC-022	Decal, Do Not Operate Below 120V
89-10	151080-49	Clamp, f/1 3/8" Din Rail (4)
89-11	ELU07-C	Dinrail, 1 3/8", 8 1/2" Long
89-12	151080-61	Terminal Block, Small (5)
89-13	600-R-01	Disconnect Switch Assembly
89-14	1534	Terminal Board
89-15	543-M-22	Switch, 4-position Selector
89-16	543-M-15	Contact Block, for Selector Switch(white) #KA-1 (not shown)
89-17	543-M-16	Contact Block for Selector Switch(red) #KA-3 (3) (not shown)
89-18	543-O-01	Switch, Pushbutton ON, Green, 12 VDC
89-19	543-O-02	Block, Switch, 12 VDC (not shown)
89-20	260302-4	Cover Plate, Weatherproof
89-21	250700-17	GFCI Outlet
89-22	433-E	Manual Reset, 15 AMP
89-23	543-M-38	Alarm for Pre-Alarm System, 24V
89-24	543-O-04	Switch, Kill
89-25	8075-1	Contact, Kill Switch (not shown)
89-26	4000-32-3	Socket, (4)
89-27	4000-32-7	Timer, On Delay
89-28	4000-32-8	Clip, Timer Relay
89-29	4000-32-2	Relay, 12VDC Cube (3)
89-30	4000-32-4	Relay Clips (3)
89-31	543-M-18	Connector, Conduit, 1/2" Straight (4)
89-32	121	Cord Clamp, 3/4"
89-33	ELU07-F	Dinrail, 1 3/8", 2 3/4" Long
89-34	543-M-77	Hour Meter
89-35	151080-62	Terminal Block, Large

## 12 V.D.C Electrical (Optional Vacuum System) Exploded Parts View

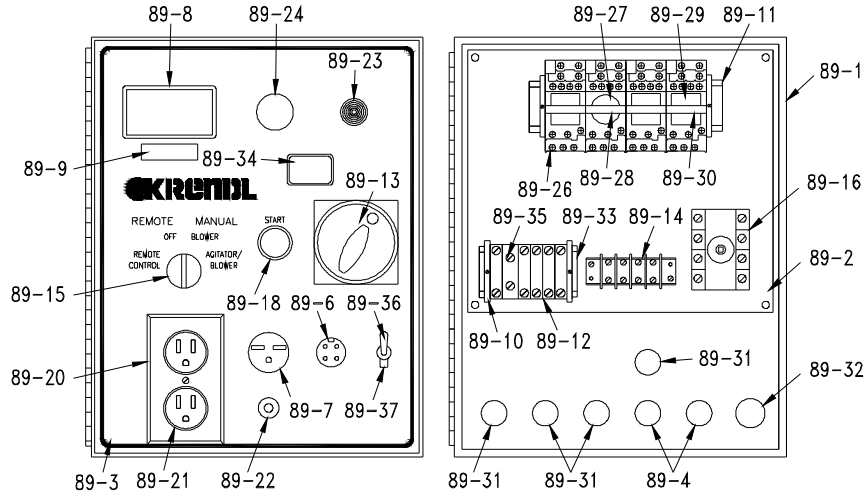

### 12 V.D.C.

Item #	Part #	Description
89-1	5200T39-R1	Box, Electrical
89-2	1563	Plate, Backing, 9" x 11 1/8"
89-3	KMC-236-R4	Decal, Electrical Box
89-4	391N-A-2	Connector, Cord, Liquid Tite, 1/2" White (2)
89-5	391N-A-3	Locknut, Steel, Conduit, 1/2" (2) (not shown)
89-6	491	Connector, 4 Pin Female (remote)
89-7	132-B	Receptacle, NEMA# 6-15R
89-8	543-M-83	Voltmeter, Digital 120V
89-9	KMC-022	Decal, Do Not Operate Below 120V
89-10	151080-49	Clamp, f/1 3/8" Din Rail (4)
89-11	ELU07-C	Dinrail, 1 3/8", 8 1/2" Long
89-12	151080-61	Terminal Block, Small (5)
89-13	600-R-01	Disconnect Switch Assembly
89-14	1534	Terminal Board
89-15	543-M-22	Switch, 4-position Selector
89-16	543-M-15	Contact Block, for Selector Switch(white) #KA-1 (not shown)
89-17	543-M-16	Contact Block for Selector Switch(red) #KA-3 (3) (not shown)
89-18	543-O-01	Switch, Pushbutton ON, Green, 12 VDC
89-19	543-O-02	Block, Switch, 12 VDC (not shown)
89-20	260302-4	Cover Plate, Weatherproof
89-21	250700-17	GFCI Outlet
89-22	433-E	Manual Reset, 15 AMP
89-23	543-M-38	Alarm for Pre-Alarm System, 24V
89-24	543-O-04	Switch, Kill
89-25	8075-1	Contactor, Kill Switch (not shown)
89-26	4000-32-3	Socket, (4)
89-27	4000-32-7	Timer, On Delay
89-28	4000-32-8	Clip, Timer Relay
89-29	4000-32-2	Relay, 12VDC Cube (3)
89-30	4000-32-4	Relay Clips (3)
89-31	543-M-18	Connector, Conduit, 1/2" Straight (4)
89-32	121	Cord Clamp, 3/4"
89-33	ELU07-F	Dinrail, 1 3/8", 2 3/4" Long
89-34	543-M-77	Hour Meter
89-35	151080-62	Terminal Block, Large
89-36	1536-3	Switch, Toggle, SPST (Switch for vacuum system)
89-37	1536-8	On/Off Plate (On/Off plate for vacuum system)

## 12 V.D.C Electrical w/No Generator Exploded Parts View

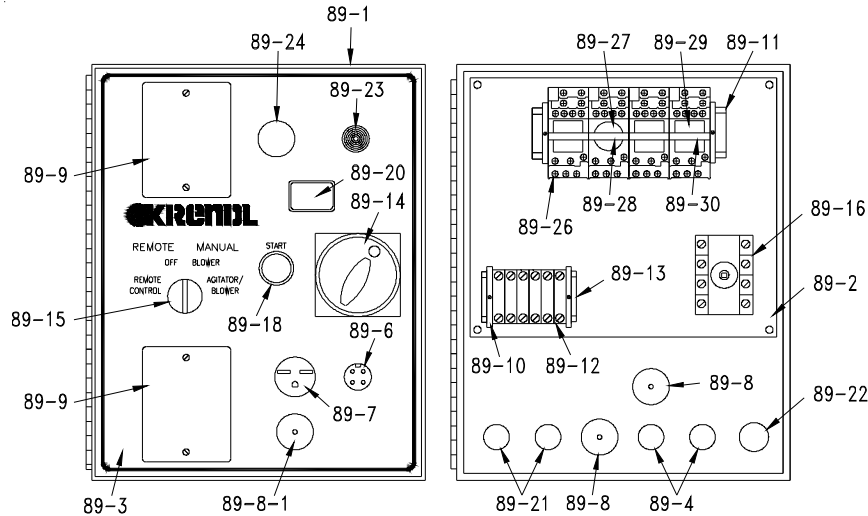

### 12 V.D.C.

Item #	Part #	Description
89-1	5200T39-R1	Box, Electrical
89-2	1563	Plate, Backing, 9" x 11 1/8"
89-3	KMC-236-R3	Decal, Electrical Box
89-4	391N-A-2	Connector, Cord, Liquid Tite, 1/2" White (2)
89-5	391N-A-3	Locknut, Steel, Conduit, 1/2" (2) (not shown)
89-6	491	Connector, 4 Pin Female (remote)
89-7	132-B	Receptacle, NEMA# 6-15R
89-8	543-M-50	Cover Plate, Tapped Hole, Round (3)
89-8-1	543-M-56	Cover Plate, Clearance Hole, Round (3)
89-9	532	Plate, Block-Off (2)
89-10	151080-49	Clamp, f/1 3/8" Din Rail (4)
89-11	ELU07-C	Dinrail, 1 3/8", 8 1/2" Long
89-12	151080-61	Terminal Block, Small (6)
89-13	ELU07-F	Dinrail, 1 3/8", 2 3/4" Long
89-14	600-R-01	Disconnect Switch Assembly
89-15	543-M-22	Switch, 4-position Selector
89-16	543-M-15	Contact Block, for Selector Switch(white) #KA-1 (not shown)
89-17	543-M-16	Contact Block for Selector Switch(red) #KA-3 (3) (not shown)
89-18	543-O-01	Switch, Pushbutton ON, Green, 12 VDC
89-19	543-O-02	Block, Switch, 12 VDC (not shown)
89-20	543-M-77	Hour Meter
89-21	543-M-18	Connector, Conduit, 1/2" Straight (2)
89-22	121	Cord Clamp, 3/4"
89-23	543-M-38	Alarm for Pre-Alarm System, 24V
89-24	508-2	Switch, Kill
89-25	8075-1	Contactor, Kill Switch (not shown)
89-26	4000-32-3	Socket, (4)
89-27	4000-32-7	Timer, On Delay
89-28	4000-32-8	Clip, Timer Relay
89-29	4000-32-2	Relay, 12VDC Cube (3)
89-30	4000-32-4	Relay Clips (3)

**Power Take Off  
Exploded Parts View**

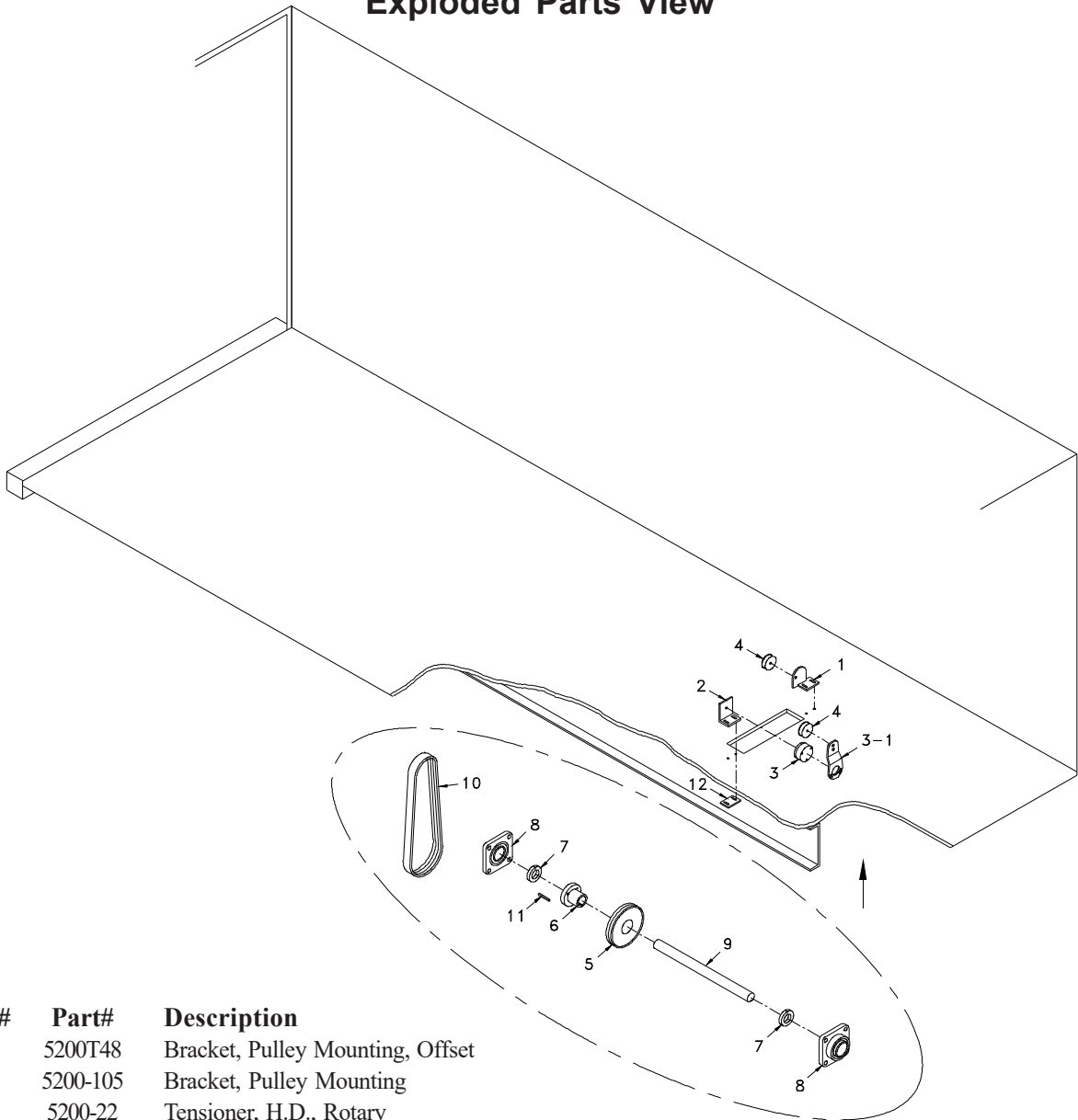

Item#	Part#	Description
1	5200T48	Bracket, Pulley Mounting, Offset
2	5200-105	Bracket, Pulley Mounting
3	5200-22	Tensioner, H.D., Rotary
3-1	GV230-33	Tensioner Arm
4	GV230-31	Idler (2)
5	5200T31	Pulley, 2GR5V10.3 SK
6	5200T33	Bushing, SK 2 1/4"
7	ST301-36	Collar, Single Split, 2 1/4" (2)
8	ST301-34	Bearing, 2 1/4" (2)
9	KS353-10	Shaft, 2 1/4" Dia., 30" long
10	5200T30	Belt, Banded, 2/5V1120 (Freightliner & International)
10	5200T106	Belt, Banded, 5V1060/02 (Isuzu)
11	KS353-13	3/8" x 1/2" Key
12	5200T49	Bracket, Mounting, Idler (2)
13	KS353	Line Drive Assy (Not Shown)

## GLOSSARY

<b>BRIDGING</b>	A tendency for fiber to cling in the hopper forming an air pocket above the airlock. This hinders the normal feeding process of the machine.
<b>CFM</b>	(Cubic feet per minute). A measurement of volume or <b>quantity</b> of air flowing at a certain rate, or air moving capability, of a blower. It is the volume of air moved per minute. Higher volume provides increased coverage and velocity of fiber as it leaves the hose.
<b>CHECK VALVE</b>	A valve that allows air to flow in one direction only. When mounted on the outlet of the blower, it protects the blower from fiber contamination through the air hose when using one blower. When the blower stops, the valve closes.
<b>COMMERCIAL SPRAY-ON</b>	The application of fiber with adhesive to a surface which will remain exposed. The application must therefore be impacted in a smooth, uniform manner.
<b>COVERAGE</b>	Refers to the amount of fiber coverage, usually measured in square feet, according to the R-value desired. This information is given on the fiber package.
<b>NEW CONSTRUCTION WALL CAVITY SPRAY</b>	The spray application of fiber with water or adhesive into an exposed wall cavity to later be covered with drywall sheathing, etc.
<b>PSI</b>	Pounds of pressure per square inch of <b>force</b> exerted on a surface by air or liquid. High-pressure blowers push the fiber through the hose. Higher pressure provides less hose plugging and increased compaction in side wall.
<b>PRODUCTION RATE</b>	Pounds of fiber blown per hour.
<b>RPM</b>	(Revolutions per minute). Speed at which the shaft of a rotating device (i.e. blower fan, agitator) is moving.
<b>R-VALUE</b>	Resistance value. A precise measurement of the insulation's resistance to heat transfer. The higher the resistance value, the slower the heat will transfer through the insulating material.
<b>RETRO-SIDEWALL</b>	This refers to the installation of fiber into an unexposed wall cavity. Fiber is usually installed through holes drilled into the exterior siding.
<b>SETTLED DENSITY</b>	The point at which the fiber will not continue to settle further. Any insulation blown will have a certain amount of progressive settling that occurs over a period of time. Following the fiber manufacturer's recommendations for bag rate coverage will provide useful information to accommodate for settling.
<b>SETTLING</b>	Compression or compaction of insulation fibers caused by the weight of the material, vibration of structure, temperature, and humidity cycles.

**SERVICE RECORD**

DATE	MAINTENANCE PERFORMED	COMPONENTS REQUIRED





# 65 YEARS OF AMERICAN INGENUITY

**Made in the U.S.A.**

---

---

**KRENDL MACHINE COMPANY • 1201 SPENCERVILLE RD  
DELPHOS, OHIO 45833 • TELEPHONE 419-459-2069 • FAX 419-695-9301  
E - MAIL: [krendl@krendlmachine.com](mailto:krendl@krendlmachine.com) • WEB SITE: [www.krendlmachine.com](http://www.krendlmachine.com)**

---

---