



# KRENDL™

The Innovator in Insulation Equipment



## OWNERS MANUAL

### MODEL #5200-3E



**65 YEARS OF AMERICAN INGENUITY**

---

**KRENDL MACHINE COMPANY • 1201 SPENCERVILLE RD  
DELPHOS, OHIO 45833 • TELEPHONE 800-459-2069 • FAX 419-695-9301  
E - MAIL: [krendl@krendlmachine.com](mailto:krendl@krendlmachine.com) • WEB SITE: [www.krendlmachine.com](http://www.krendlmachine.com)**

---

**CONGRATULATIONS ON YOUR PURCHASE OF KRENDL EQUIPMENT**

**MODEL #5200-3E  
OWNER'S MANUAL**

FOR ASSURED SAFETY AND CONFIDENCE, PLEASE READ THIS MANUAL CAREFULLY BEFORE INSTALLING AND OPERATING YOUR MACHINE.

**E-MAIL ADDRESS IS: [krendl@krendlmachine.com](mailto:krendl@krendlmachine.com)  
WEB SITE IS: [www.krendlmachine.com](http://www.krendlmachine.com)**

# Table of Contents

|  |       |
|--|-------|
| INTRODUCTION .....                     | 1     |
| UNPACKING & INSPECTING EQUIPMENT ..... | 2     |
| GENERAL SAFETY INFORMATION .....       | 2-5   |
| DECALS .....                           | 6-7   |
| WARRANTY .....                         | 8     |
| RETURNED GOODS PROCEDURE .....         | 9     |
| SPECIFICATIONS .....                   | 9     |
| BASIC COMPONENTS .....                 | 10    |
| OPERATING INSTRUCTIONS .....           | 11-14 |
| GENERAL MAINTENANCE .....              | 15-18 |
| ELECTRICAL SYSTEM .....                | 19    |
| TROUBLESHOOTING .....                  | 20-21 |
| SPARE PARTS LIST .....                 | 21    |
| PARTS LIST .....                       | 22-27 |
| GLOSSARY .....                         | 28    |
| SERVICE RECORD .....                   | 29    |

## INTRODUCTION

Thank you for purchasing a **KRENDL INSULATION MOVING MACHINE**. With over sixty five years experience in manufacturing insulation moving equipment, we have designed and built your machine with the highest quality parts and workmanship to provide years of reliable service.

This manual has been prepared to help you obtain the maximum efficiency and service from your Krendl equipment. The machine is designed to condition and apply insulation with the utmost in dependable performance. Our primary objective is to build equipment which will provide complete satisfaction so that you may confidently recommend Krendl to others.

We do not manufacture or sell insulation. Our interest lies only in the proper performance of the equipment we manufacture. The insulation material manufacturer's instructions prevail when it comes to applying their product, since they guarantee the final results.

This manual contains important information regarding the safe assembly and operation of your machine. We urge you to read it carefully and **THOROUGHLY** before putting your machine to work. If your questions are not answered in this manual, please contact us. We want you to be able to operate this equipment safely and confidently.

Upon receipt of this machine, check it carefully for any shipping damage. If there is damage or if any of the parts are missing, notify the delivery trucking company immediately and file a claim for damages, saving all packaging materials for inspection. Our warranty covers manufacturer's defects only. If Krendl Machine Company delivered or set up your machine and any parts are missing or damaged, notify the authorized representative before they leave.

Krendl Machine Company  
1201 Spencerville Rd  
Delphos, Ohio 45833 U.S.A.

Telephone: 800-459-2069  
Fax: 419-695-9301  
E-Mail: [krendl@krendlmachine.com](mailto:krendl@krendlmachine.com)  
Web Site: [www.krendlmachine.com](http://www.krendlmachine.com)

For your protection in the event of theft or loss, please fill in the information requested for your own records. This information will be needed for in-warranty repairs. You may also want to attach a copy of your invoice.

Machine Model No. \_\_\_\_\_

Machine Serial No. \_\_\_\_\_

Blower Manufacturer \_\_\_\_\_

Blower Model No., Serial No. \_\_\_\_\_

## UNPACKING AND INSPECTING EQUIPMENT

### RECEIVING YOUR MODEL #5200-3E KRENDL MACHINE:

Immediately check the condition of your Model #5200-3E machine when it is received. It should be received in the same condition that it was shipped to you. **If there are any visible problems with your machine or any other items in the shipment, it is imperative that you place any claim with the delivery carrier.** Please save all packaging materials for inspection. The delivery carrier should also contact our office before leaving the premises to notify us of a claim. The ownership to your machine and all other items in the shipment were transferred to your name as soon as the shipment left our premises, thus it is your responsibility to contact us with any claims. Contact the truck line to arrange for an independent inspector to come out to inspect the damage and to prepare the inspection report. It is imperative that this inspection is done prior to unpacking or using any of the equipment. Please contact us for assistance in parts or with any questions you may have regarding the claim process.

### UNPACKING:

Handle all cartons with care to avoid damage from dropping or bumping. Completely remove machine from the packaging and from any shipping pallet or skid to which it might be attached. In addition, completely remove all shipping materials from inside the machine. Check that all parts are included as stated on the packaging list.

### ACCESSORIES INCLUDED:

- 150' REMOTE CONTROL CORD
- MULTIMETER
- #60 CHAIN MASTER LINK
- SECTION OF CHAIN FOR CHANGING SHREDDER DIRECTION
- 5/16 ALLEN WRENCH FOR ADJUSTMENT OF CHAIN IDLERS
- OWNERS MANUAL

## GENERAL SAFETY INFORMATION



**Important:** Read **all** instructions **before** operating this unit. This equipment can be potentially dangerous and must be used in strict accordance with instructions.



**Disclaimer Notice:** The manufacturer will not be legally responsible for any injury or damage resulting from the improper use of this equipment or the failure to follow instructions.

### Unpacking

Handle cartons with care to avoid damage from dropping or bumping. Completely remove the machine from the packaging and from any shipping pallet or skid to which it may be attached. In addition, completely remove all shipping materials from the **inside** of the machine.



**Important:** Please recheck inside the hopper for any loose items or damaged equipment. Injury may occur when equipment is started with foreign material in the hopper.



### **General Safety**

1. Read this manual carefully and become familiar with your machine. It is important to know it's applications, limitations, and any hazards involved prior to operating the machine.
2. This machine was designed and manufactured for blowing cellulose and fiberglass. Do not attempt to modify the unit or use it for any application it was not designed for. If you have any questions about your intended use or the machine's suitability, ask your dealer/distributor or consult the factory. The manufacturers could not possibly anticipate every circumstance that might involve a hazard. For that reason, warnings in the manual and warning tags or decals affixed to the unit, are not all-inclusive. If you intend to handle, operate, or service the unit by a procedure or a method not specifically recommended by the manufacturer, first make sure that such a procedure or method will not render this equipment unsafe or pose a threat to you and others.
3. Do not disable any of the safety features on our machinery. These features are for your protection and safety.
4. Read and obey all safety and operating instructions in the manual and on the machine.
5. Equipment is to be operated and/or maintained by TRAINED & QUALIFIED personnel ONLY!!
6. Do not operate the machine without all guards and safety equipment installed in the proper location and in working order. Always follow the proper shut down procedures when guards are removed from the machine.
7. If a malfunction occurs while running the machine, turn it off immediately and correct the problem prior to restarting the machine.
8. Keep body and all clothing away from rotating equipment. Rotating shafts can be dangerous.
9. Always wear proper safety equipment when operating the machine. This includes steel toed shoes, safety glasses and a respirator.
10. Under no circumstances should your hand, a stick or a broom be used to force material down into the hopper. The machine is a self feeding design and requires no outside assistance.
11. Stand on the floor, not a platform while operating the machine. The operator may lose balance and fall while loading bags of material.

All Model #5200 Machines are factory equipped with side, front, and main drive belt guards. The top of the machine is not guarded since it poses no safety threat for normal insulation blowing operations.

Always turn the main power switch (located on the electrical box) to off and unplug the remote cord from the receptacle for any type of machine maintenance or adjustments. An additional safety feature is the ability to adjust the material slide gate from the outside of the machine. Rotate the adjustment handle clockwise to open the slide to the desired setting, no entrance into the machine is required.

**All safety features are incorporated into the machine to protect everyone from serious injury. Operate your machine according to the outlined instructions in the manual with all guards in place and securely latched. Operation with any guards removed or open can result in injury to or loss of fingers, hands, arms, toes, feet, legs, hair, and even your eyes.**

**Electrical Safety**

- The **National Electric Code** (NEC) in the United States and many international electrical codes require frame and external electrically conductive parts of this machine to be properly connected to an approved earth ground. Local electrical codes may also require proper grounding of machine. Consult with local electricians for grounding requirements in your area.
- Never handle any kind of electrical cord or device while standing in water, while barefoot or while hands or feet are wet. Dangerous electrical shock will result.
- Use a ground fault circuit interrupter (GFCI) in any damp or highly conductive area. (metal decking or steel work)
- Reference NFPA 79, 70E, or OSHA safe work practices when performing energized work procedures.

**Safety/Caution**

- **Be Safe** - Keep away from moving parts.
- **Be Safe** - Make sure all guards and hopper extensions are in proper place **before** operating machine. Guards and safety devices/switches should not be removed, modified or by-passed. Hands should never pass between rotating parts.
- **Be Safe** - Make sure remote control hand pendant switch is in **off** position **before** connecting the power supply to the machine.
- **Be Safe** - Make sure machine is properly grounded. Protect all electrical supply cords from sharp objects, moisture, and other potentially hazardous materials. Keep power cords in good repair. Electrical service must be performed by a qualified electrician.
- **Be Safe** - Disconnect power supply **before** inspecting or adjusting unit.
- **Be Safe** - Consult a qualified technician to answer questions **before** attempting to operate, or injury may result.
- **Be Safe** - **Emergency Kill Switch** - In case of emergencies, always use red stop button located on the front of Main Control Panel and on the side of the hopper. It will stop all feeding and agitation.
- **Be Safe** - Do not remove motors or lift hopper when unit is connected to power supply.
- **Be Safe** - Do not operate machine alone.
- **Be Safe** - Do not leave machine unattended and energized.
- **Be Safe** - Turn machine off and disconnect electricity before clearing and feeding jam or attempting to remove any object dropped in the hopper.
- **Be Safe** - Keep hands, loose clothing, jewelry and hair away from agitators, gears, chains and other moving parts.
- **Be Safe** - Use proper lifting when moving insulation and loading machine.
- **Be Safe** - Keep work area clear of debris.
- **Be Safe** - Wear proper safety equipment, including protective gear, such as respirators, eye and ear protection.
- **Be Safe** - Violation of the Owner's Manual or safety precautions may void warranty.

**Make Sure!**

- Hopper is empty of foreign objects **before** starting.
- Adequate electrical power is supplied or damage to unit will result.
- Machine must be on **before** adding insulation.
- Blower filter is kept clean and in place when blower is on.
- Machine is turned off **immediately** if hose is plugged, or blower will overheat.
- Blower must be on, when agitators are running, or machine will bind.
- Agitator motor is not run with hopper empty for more than a few minutes, or damage to seals will result.
- Sprockets, chains, belts and pulleys are correctly **aligned** and **tensioned**.
- Pieces of bag are **not** left in the machine as this can bind and stall your machine.
- This machine should only be used with good quality insulation that is dry, undamaged and that meets a certain industry specification or quality standards.

**IF THERE ARE ANY QUESTIONS WITH YOUR KRENDL MACHINE, DO NOT HESITATE TO  
CONTACT US AT: 1-800-459-2069**



## DECALS



Keeping the filter clean will result in longer blower life and better performances.



Rotating parts can be dangerous! You can snag clothes, hair, hands, etc. This can cause serious injury or death.



Becareful around electrical components! This can cause serious injury or death.

|   |   |
|---|---|
| <p><b>ALL FIBER MACHINES</b></p> <p><b>IMPORTANT:</b> READ ALL INSTRUCTIONS BEFORE OPERATING THIS UNIT. THIS EQUIPMENT CAN BE POTENTIALLY DANGEROUS AND MUST BE USED IN STRICT ACCORDANCE WITH INSTRUCTIONS.</p> <p><b>DISCLAIMER NOTICE:</b> THE MANUFACTURER WILL NOT BE LEGALLY RESPONSIBLE FOR ANY INJURY OR DAMAGE RESULTING FROM THE IMPROPER USE OF THIS EQUIPMENT OR THE FAILURE TO FOLLOW INSTRUCTIONS. (REFER TO ADDITIONAL INSTRUCTIONS PROVIDED.)</p> <p><b>CAUTION-BE SAFE</b></p> <ul style="list-style-type: none"> <li>KEEP AWAY FROM MOVING PARTS.</li> <li>MAKE SURE ALL GUARDS AND HOPPER BARS ARE IN PROPER PLACE BEFORE OPERATING MACHINE. HANDS SHOULD NEVER PASS BELOW HOPPER BARS.</li> <li>MAKE SURE BLOWER MOTOR AND AGITATOR MOTOR SWITCHES ARE IN OFF POSITION BEFORE CONNECTING THE POWER SUPPLY TO THE MACHINE.</li> <li>MAKE SURE MACHINE IS PROPERLY GROUNDED. PROTECT POWER CABLE FROM SHARP OBJECTS, MOISTURE, AND OTHER POTENTIALLY HAZARDOUS MATERIALS. KEEP POWER CORDS IN GOOD REPAIR. ELECTRICAL SERVICE MUST BE PERFORMED BY A QUALIFIED ELECTRICIAN.</li> <li>DISCONNECT POWER SUPPLY BEFORE INSPECTION OR ADJUSTMENT TO UNIT. DO NOT REMOVE BLOWER OR HOPPER WHEN UNIT IS CONNECTED TO POWER SUPPLY.</li> <li>CONSULT A QUALIFIED PERSON TO ANSWER QUESTIONS BEFORE ATTEMPTING TO OPERATE OR INQUIRY MAY RESULT.</li> </ul> <p><b>IMPORTANT- MAKE SURE</b></p> <ul style="list-style-type: none"> <li>ADEQUATE ELECTRICAL POWER IS SUPPLIED OR DAMAGE TO UNIT WILL RESULT.</li> <li>BLOWER IS TO BE KEPT CLEAN AND IN PLACE WHEN BLOWER IS ON.</li> <li>BLOWER IS ON WHILE AGITATOR IS RUNNING, OR MACHINE WILL PLUG.</li> <li>BLOWER IS TURNED OFF IMMEDIATELY IF HOSE IS PLUGGED, OR BLOWER WILL OVERHEAT.</li> <li>AGITATOR MOTOR IS ON BEFORE AGGING FIBER.</li> <li>AGITATOR MOTOR IS NOT RUN WITH HOPPER EMPTY FOR MORE THAN A FEW MINUTES, OR DAMAGE TO REALS WILL RESULT.</li> <li>BELTS OR CHAINS ARE CORRECTLY ADJUSTED AND TENSIONED.</li> </ul> | <p><b>TODAS LAS MÁQUINAS DE FIBRA</b></p> <p><b>IMPORTANTE:</b> ES IMPORTANTE LEER TODAS LAS INSTRUCCIONES ANTES DE OPERAR ESTA UNIDAD. ESTE EQUIPO PUEDE SER POTENCIALMENTE PELIGROSO Y SE DEBERÁ USAR ESTRICTAMENTE DE ACUERDO CON LAS INSTRUCCIONES.</p> <p><b>AVISO DE RESPONSABILIDAD LEGAL:</b> EL FABRICANTE NO SERÁ LEGALMENTE RESPONSABLE POR NINGÚN PELIGRO O DAÑO RESULTANTE POR EL USO INAPROPIADO DE ESTE EQUIPO O LA INOBERSIANCIA DE LAS INSTRUCCIONES. (CONSULTE A LAS INSTRUCCIONES ADICIONALES SUMINISTRADAS)</p> <p><b>PRECAUCIÓN-NO CORRA RIEGOS</b></p> <ul style="list-style-type: none"> <li>MANTÉNGASE ALEJADO DE LAS PARTES EN MOVIMIENTO.</li> <li>ASEGURESE DE QUE TODAS LAS PROTECCIONES Y LAS BARRAS DE LA TOLVA ESTÉN EN EL LUGAR CORRECTO ANTES DE OPERAR LA MÁQUINA. LAS MANOS JAMÁS DEBEN PASAR POR DEBAJO DE LAS BARRAS DE LA TOLVA.</li> <li>ASEGURESE DE QUE LOS INTERRUPTORES DEL MOTOR DE SOPLADOR Y DEL AGITADOR ESTÉN EN LA POSICIÓN OFF ANTES DE CONECTAR EL SUMINISTRO DE ENERGÍA A LA MÁQUINA.</li> <li>ASEGURESE DE QUE LA MÁQUINA ESTE PUESTA A TIERRA ADECUADAMENTE. PROTEJA EL CABLE DE ENERGÍA DE OBJETOS CORPÓREOS, HUMEDAD, Y OTROS MATERIALES POTENCIALMENTE PELIGROSOS. CONECTE LOS CABLES DE ENERGÍA EN BUENA FORMA. EL MANTENIMIENTO ELÉCTRICO DEBE ESTAR A CARGO DE UN ELECTRICISTA CALIFICADO.</li> <li>DESCONECTE EL SUMINISTRO DE ENERGÍA ANTES DE INSPECCIÓN O AJUSTE DE LA UNIDAD.</li> <li>NO OPERE EL SOPLADOR O LA TOLVA CUANDO LA UNIDAD ESTÁ CONECTADA AL SUMINISTRO DE ENERGÍA.</li> <li>CONSULTE A SU OBRERO A UNA PERSONA CALIFICADA ANTES DE INTENTAR OPERAR LA MÁQUINA SI ALGUNO PUEDE LESIONARLA.</li> </ul> <p><b>IMPORTANTE-ASEGURESE DE</b></p> <ul style="list-style-type: none"> <li>QUE SE SUMINISTRE LA ENERGÍA ELÉCTRICA ADECUADA O SE DAÑARÁ EL EQUIPO.</li> <li>QUE EL FILTRO DEL SOPLADOR SE MANTIGA LIMPIO Y EN SU LUGAR CUANDO EL SOPLADOR ESTE FUNCIONANDO.</li> <li>QUE EL SOPLADOR FUNCIONE MIENTRAS EL AGITADOR ESTE EN MARCHA, O LA MÁQUINA SE TAPONARÁ.</li> <li>QUE EL SOPLADOR SE DETENGA INMEDIATAMENTE SI LA MANGUERA SE TAPA O EL SOPLADOR SE RECALENTA.</li> <li>QUE EL MOTOR DEL AGITADOR ESTE FUNCIONANDO ANTES DE AGREGAR FIBRA.</li> <li>QUE EL MOTOR DEL AGITADOR NO FUNCIONE CON LA TOLVA VACÍA MÁS QUE UNOS POCOS MINUTOS O SE DAÑARÁN LOS DEDOS.</li> <li>QUE LAS CORREAS O CADENAS ESTÉN CORRECTAMENTE AJUSTADAS Y TENSIONADAS.</li> </ul> |
|---|---|

General safety information intended to reduce the risk of serious injury or death

**Note:** This equipment to be used in the application of Cellulose, Fiberglass, Rockwool Insulation. KMC-045-R1

**Nota:** Este equipo será usado en la aplicación de aislamientos de celulosa, fibra de vidrio y lana de roca.

**Notice:** For assured safety and confidence, please read the manual before operating. If no manual is provided a free download is available at [www.krendlmachine.com](http://www.krendlmachine.com) or by contacting Krendl Machine at 419-692-3060.

**Aviso:** Para una mejor seguridad y confianza, por favor lea el manual antes de operar. Si no se proporciona un manual, se puede descargar gratuitamente de [www.krendlmachine.com](http://www.krendlmachine.com) o contactando a la empresa Krendl Machine 419-692-3060.

**Warning:** NEVER HANDLE ANY KIND OF ELECTRICAL CORD OR DEVICE WHILE STANDING IN WATER, WHILE BAREFOOT OR WHILE HANDS AND OR FEET ARE WET. DO NOT USE ELECTRICAL DEVICES IN INCLEMENT WEATHER. DANGEROUS ELECTRICAL SHOCK OR DEATH WILL RESULT.

**Advertencia:** NUNCA MANPUELE NINGÚN TIPO DE DISPOSITIVO O CABLE ELÉCTRICO MIENTRAS ESTÁ DE PIE SOBRE AGUA, MIENTRAS ESTÁ DESCALZO O CON LAS MANOS O PIES HÚMEDOS. NO USE DISPOSITIVOS ELÉCTRICOS EN CLIMA INCLEMENTE. PUEDE TRAER COMO RESULTADO CHOQUES ELÉCTRICOS PELIGROSOS O LA MUERTE.

Identifies what type of insulation should be used with this machine and that the manual should be read before operating. Warns to be careful around electrical components! This can cause serious injury or death.



Made in the U.S.A.



Emergency stop button for machine.



Identifies air adjustment control.



Indicates if blower is off, on, or on with agitator.

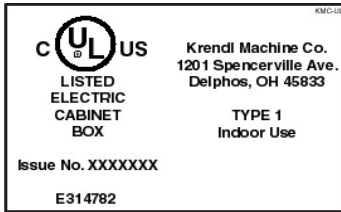

Indicates that the electrical box on the machine is in compliance with UL codes.



Opens and closes the material feed gate which in turn controls the production.



Indicates which employee inspected equipment and on what date.

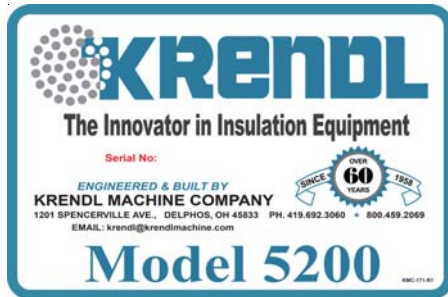

Manufacturer information is provided here along with machine model, and serial number.



Identifies position of material feed gate.



Part number for identification and tracking.



Monthly maintenance schedule for the greasing of bearings on the agitators, shredders and airlock.



Rotating parts will be moving in this direction.



Identifies if machine is in remote mode, manual mode, or off position. In manual mode this switch operates machine. In remote mode the hand pendant operates machine. Each time machine cycle starts, an audible alarm warns the operator that the machine is about to come on.



Specifies the voltage this outlet is rated for.



Overload OK light indicates overloads are not tripped.



Power light indicates machine is ready to run.



Indicates that this outlet is intended for only the remote control outlet. Each time machine cycle starts, an audible alarm warns the operator that the machine is about to come on.

**WARRANTY:**

Krendl Machine Company (Company) warrants to each original purchaser (Buyer) of its machines that such products will be free of manufacturing defects for a period of 2 years from the date of shipment to the Buyer. (This does not include accessories, pumps, blowers, wall scrubbers, etc.)

No warranty is made with respect to:

1. Components or accessories manufactured and warranted by others. Warranties for purchased component parts as supplied from vendor such as engine, electric motor, blower, gearbox, transmission, etc., if furnished by the manufacturer of the component, are on file at the Company's main office and copies will be furnished at request of Buyer. Component(s), shipping costs prepaid, shall be sent to Company who in turn shall forward to vendor for evaluation and warranty determination.
2. Any defect caused by repair, alteration and/or adjustment performed by Buyer or customer/vendor of Buyer without the express written authorization of the Company.
3. The labor costs of replacing parts by parties other than the Company.
4. Any machine that has not been operated and/or maintained in accordance with normal industry practice and the written recommendations of the Company. (e.g. machine operated with an improperly sized, worn or damaged hose, improper or inattention to preventative maintenance, etc.)
5. The product has been subjected to misuse, negligence or accident or results of any application or use of the blowing equipment not in accordance with the Company recommendations.

This limited warranty does not cover the free replacement of component parts that become inoperative due to wear and usage and need to be replaced on a regular basis, including but not limited to: airlock seal(s), agitator(s), shredder(s), auger(s), fuse(s), switch(es), clutch(es), hose(s), shaft seal(s), chain(s), belt(s), sprocket(s), pulley(s), bearing(s), cable(s), battery(ies), filter(s), fan(s), etc.

The Company's obligation under this warranty is limited to repairing or replacing (at Company option) any part that is determined by the Company to be suffering from a manufacturing defect. The Company (at Company option) will provide any required parts and labor to the Buyer. If the equipment or parts must be returned to the Company for repair, all transportation costs shall be the Buyer's responsibility.

**THIS LIMITED WARRANTY IS EXPRESSLY IN LIEU OF ANY OTHER GUARANTEES AND / OR WARRANTIES, ORAL OR WRITTEN, EXPRESSED OR IMPLIED, INCLUDING WITHOUT LIMITATION, THE IMPLIED WARRANTY OF MERCHANTABILITY. NO WARRANTY, EXPRESS OR IMPLIED, OTHER THAN THE AFORESAID WARRANTY IS MADE OR AUTHORIZED BY COMPANY. COMPANY SHALL NOT BE LIABLE FOR ANY DIRECT, INDIRECT, INCIDENTAL OR CONSEQUENTIAL DAMAGES TO PROPERTY OR INJURY TO ANY PERSON OR COSTS ASSOCIATED WITH LOSS OF PRODUCTION RESULTING IN LOSS OF REVENUE, PROFITS OR LOSS OF EQUIPMENT THROUGH THE USE OF THIS EQUIPMENT.**

**Note: Special job circumstances incurring costs for specialized repair and next day delivery of parts will not be reimbursed by the manufacturer unless authorized by factory.**

**RETURNED GOODS PROCEDURE**

IF MACHINE WAS NOT PURCHASED DIRECTLY FROM KRENDL MACHINE COMPANY, CONTACT YOUR SUPPLIER / DISTRIBUTOR.

When returning products to Krendl for repair, first obtain a return goods authorization (RGA), at which time you will be given shipping instructions. The product must be shipped **PREPAID**:

**Krendl Machine Company**  
1201 Spencerville Rd  
Delphos, Ohio 45833 U.S.A.

Telephone: 800-459-2069  
Fax: 419-695-9301  
E-mail: [krendl@krendlmachine.com](mailto:krendl@krendlmachine.com)  
Web Site: [www.krendlmachine.com](http://www.krendlmachine.com)

Once the unit is received, it will be inspected. In-warranty units will be repaired and returned immediately. An estimate of repair charges will be provided for out-of-warranty units.

**SPECIFICATIONS**

|                            |   |
|----------------------------|---|
| <b>MODELS:</b>             | #5200-3E  |
| <b>MACHINE:</b>            | 14" Diameter x 18" Length airlock feeder<br>air volume control system |
| <b>HEIGHT:</b>             | 83.00 inches  |
| <b>LOAD HEIGHT:</b>        | 63.50 inches  |
| <b>WIDTH (DEPTH):</b>      | 53.00 inches  |
| <b>LENGTH:</b>             | 79.00 inches  |
| <b>WEIGHT:</b>             | 1930 pounds   |
| <b>ELECTRICAL:</b>         | Primary - 480 volt 3-phase  |
| <b>BLOWER VOLUME:</b>      | 270 CFM   |
| <b>BLOWER PRESSURE:</b>    | 5.0 PSI maximum   |
| <b>HOSE OUTPUT:</b>        | 4" diameter   |
| <b>MAXIMUM FEED RATES:</b> | <b>(Product rates vary depending upon product density)</b>            |
| <i>CELLULOSE:</i>          | 5200 lbs./hr.   |
| <i>FIBERGLASS:</i>         | 2300 lbs./hr.   |

**WARNING:** Recommended hose size, type and length must be used to achieve maximum results. Krendl cannot guarantee performance of the #5200-E machine if hoses are undersized, worn, damaged, or hoses other than those we recommend are used.

**BEFORE YOU RUN THIS MACHINE...PLEASE READ THE REST OF THIS MANUAL!!**

**BASIC COMPONENTS**

This is a view of the basic components of your Model #5200-3E machine. It shows the location of each item and gives the function of each. Use this as a guide throughout the manual.

**(Illustration 1)**

- A) Base Unit** - Lower frame unit supporting blower box, speed reducer, motor, airlock and hopper.
- B) Airlock** - Traps air and insulation while providing a metered flow.
- C) Shredder System** - Increases production and coverage on all insulation products while reducing clumps that may exist in various insulations.
- D) Slidegate** - Meters the amount of insulation dropping into the airlock by controlling size of airlock opening.
- E) Speed Reducer** - Increases output power while decreasing speed of agitator/airlock drive motor.
- F) Agitator** - Conditions insulation in the hopper.
- G) Hopper** - Upper unit of machine holding insulation.

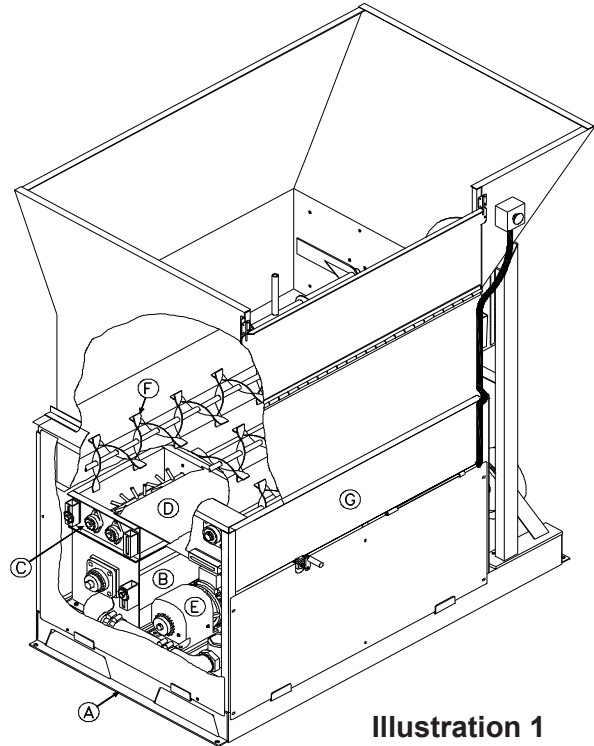
**Illustration 1****(Illustration 2)**

- H) Main Control Panel** - Connects with main power, allowing operation of unit at machine or Remote Cord.
- I) Blower** - Provides the air necessary to move insulation from the airlock.
- J) Kill Switch** - Safety device for immediate stopping of machine.
- K) Hopper Extension** - Increases overall hopper capacity.

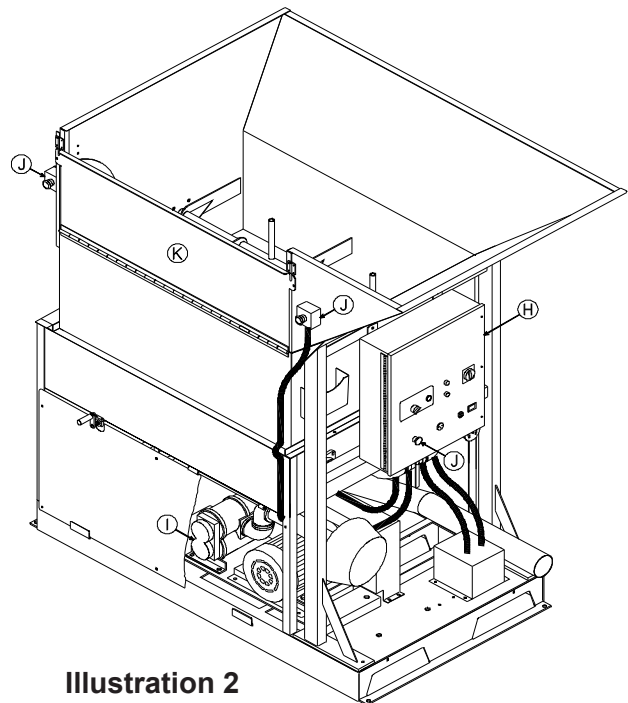
**Illustration 2**

## OPERATING INSTRUCTIONS

### Starting Your Krendl Model 5200-3E Machine:

- 1) After installing your Model #5200-3E according to the installation instructions, it is now time to start your machine. Again, check that all guards are installed properly.
- 2) Attach the blowing hose to the machine and run the hose to end location where material blowing will occur.
- 3) Run the remote control cord and locate where the operator will be situated.
- 4) Make sure the control switch on the remote control cord is in the "off" position. Now, you may plug in the remote control cord.
- 5) Your machine is now ready for operation.

**Note:** Agitator motor and blower should only be operated with steady or constant flow of electricity between 110-120 volts.

**Note:** When using extension cords, wire gauge size should not be less than input cord on unit and not exceed 50' in length. **(See Voltage Drop Chart Below.)**

| VOLTAGE DROP CHART  |        |        |       |       |       |       |       |       |
|---|--------|--------|-------|-------|-------|-------|-------|-------|
| Typical voltage drop values based on conductor size and one-way length* (60 C termination and insulation) |        |        |       |       |       |       |       |       |
| 25 FEET   |        |        |       |       |       |       |       |       |
| AMPERES   | 12 AWG | 10 AWG | 8 AWG | 6 AWG | 4 AWG | 3 AWG | 2 AWG | 1 AWG |
| 20  | 1.98   | 1.24   | 0.78  | 0.49  | 0.31  | 0.25  | 0.19  | 0.15  |
| 30  |        | 1.86   | 1.17  | 0.74  | 0.46  | 0.37  | 0.29  | 0.23  |
| 40  |        |        | 1.56  | 0.98  | 0.62  | 0.49  | 0.39  | 0.31  |
| 50  |        |        |       | 1.23  | 0.77  | 0.61  | 0.49  | 0.39  |
| 60  |        |        |       |       | 0.93  | 0.74  | 0.58  | 0.46  |
| 50 FEET   |        |        |       |       |       |       |       |       |
| AMPERES   | 12 AWG | 10 AWG | 8 AWG | 6 AWG | 4 AWG | 3 AWG | 2 AWG | 1 AWG |
| 20  | 3.95   | 2.49   | 1.56  | 0.98  | 0.62  | 0.49  | 0.39  | 0.31  |
| 30  |        | 3.73   | 2.34  | 1.47  | 0.93  | 0.74  | 0.58  | 0.46  |
| 40  |        |        | 3.13  | 1.97  | 1.24  | 0.98  | 0.78  | 0.62  |
| 50  |        |        |       | 2.46  | 1.55  | 1.23  | 0.97  | 0.77  |
| 60  |        |        |       |       | 1.85  | 1.47  | 1.17  | 0.92  |
| 75 FEET   |        |        |       |       |       |       |       |       |
| AMPERES   | 12 AWG | 10 AWG | 8 AWG | 6 AWG | 4 AWG | 3 AWG | 2 AWG | 1 AWG |
| 20  | 5.93   | 3.73   | 2.34  | 1.47  | 0.93  | 0.74  | 0.58  | 0.46  |
| 30  |        | 5.59   | 3.52  | 2.21  | 1.39  | 1.1   | 0.87  | 0.69  |
| 40  |        |        | 4.69  | 2.95  | 1.85  | 1.47  | 1.17  | 0.92  |
| 50  |        |        |       | 3.69  | 2.32  | 1.84  | 1.46  | 1.16  |
| 60  |        |        |       |       | 2.78  | 2.21  | 1.75  | 1.39  |
| 100 FEET  |        |        |       |       |       |       |       |       |
| AMPERES   | 12 AWG | 10 AWG | 8 AWG | 6 AWG | 4 AWG | 3 AWG | 2 AWG | 1 AWG |
| 20  | 7.90   | 4.97   | 3.13  | 1.97  | 1.24  | 0.98  | 0.78  | 0.62  |
| 30  |        | 7.46   | 4.69  | 2.95  | 1.85  | 1.47  | 1.17  | 0.92  |
| 40  |        |        | 6.25  | 3.93  | 2.47  | 1.96  | 1.56  | 1.23  |
| 50  |        |        |       | 4.92  | 3.09  | 2.45  | 1.94  | 1.54  |
| 60  |        |        |       |       | 3.71  | 2.94  | 2.33  | 1.85  |
| 125 FEET  |        |        |       |       |       |       |       |       |
| AMPERES   | 12 AWG | 10 AWG | 8 AWG | 6 AWG | 4 AWG | 3 AWG | 2 AWG | 1 AWG |
| 20  | 9.88   | 6.21   | 3.91  | 2.46  | 1.55  | 1.23  | 0.97  | 0.77  |
| 30  |        | 9.32   | 5.66  | 3.69  | 2.32  | 1.84  | 1.46  | 1.16  |
| 40  |        |        | 7.81  | 4.92  | 3.09  | 2.45  | 1.94  | 1.54  |
| 50  |        |        |       | 6.15  | 3.66  | 3.06  | 2.43  | 1.93  |
| 60  |        |        |       |       | 4.64  | 3.68  | 2.92  | 2.31  |
| 150 FEET  |        |        |       |       |       |       |       |       |
| AMPERES   | 12 AWG | 10 AWG | 8 AWG | 6 AWG | 4 AWG | 3 AWG | 2 AWG | 1 AWG |
| 20  | 11.85  | 7.46   | 4.69  | 2.95  | 1.85  | 1.47  | 1.17  | 0.92  |
| 30  |        | 11.18  | 7.03  | 4.42  | 2.78  | 2.21  | 1.75  | 1.39  |
| 40  |        |        | 9.38  | 5.90  | 3.71  | 2.94  | 2.33  | 1.85  |
| 50  |        |        |       | 7.37  | 4.64  | 3.68  | 2.92  | 2.31  |
| 60  |        |        |       |       | 5.56  | 4.41  | 3.50  | 2.77  |

Ex: A two-wire 20-ampere circuit using 12 AWG with a one-way distance of 25 feet will drop 1.98 volts;  
 120 volts - 1.98 volts = 118.02 volts as the load voltage.  
 480 volts - 1.98 volts = 478.02 volts as the load voltage

**Electrical Operation:**

**NOTE: PRESS KILL SWITCH TO IMMEDIATELY STOP MACHINE AT ANY TIME!**

1. Make sure Kill Switch is out by pulling. (See illustration 3)
2. Turn *red* Main Disconnect Switch to ON position. (See illustration 3)
3. Set 4-Position Selector Switch to OFF. (See illustration 3)
4. Press *green* start Button. **Machine will not run unless start button is pressed after Kill Switch is out and red Main Disconnect Switch is on.** (See illustration 3)
5. Select operating mode on 4-Position Selector Switch from one of the following options:

- Remote:** Remote control hand pendant will control machine.
- Off:** Machine will not run. (overrides remote hand pendant)
- Blower:** Only the blower will run continuously. (manual control at machine)
- Agitator-Feed/Blower:** Both the blower and the agitator-feed will run continuously. (manual control at machine)

**Main Control Panel (lid closed)**

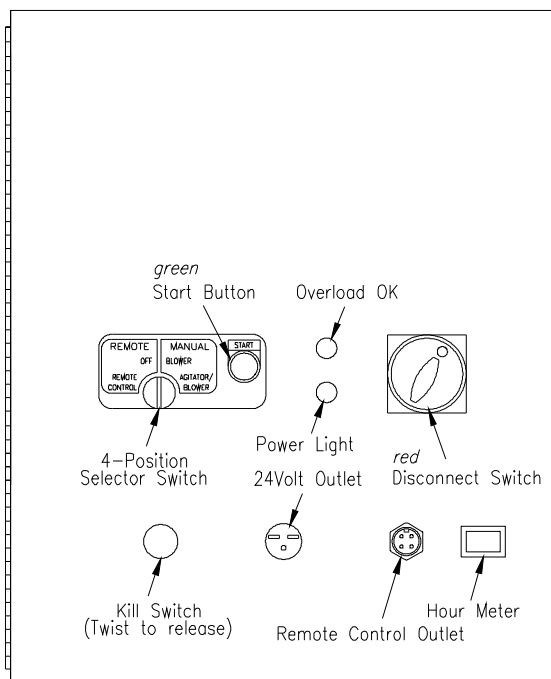

**Main Control Panel (lid opened)**

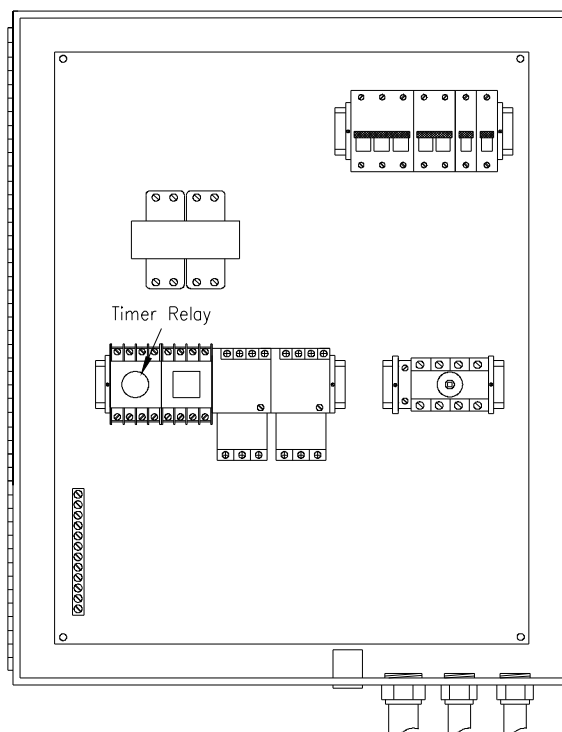

**Illustration 3**

6. When operating in **Remote mode**, the 4-Position Selector Switch must be set to **Remote** position. (See illustration 3 on page 12.)
7. Remote control hand pendant positions will be selected from the following:

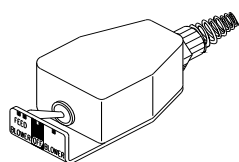

- BLOWER-FEED** - operates both **blower** and **agitator-feed** simultaneously
- OFF** - (middle position) all functions stop
- BLOWER** - operates the **blower** only

8. Use the Auxiliary Outlet on the Main Control Panel for supplying **continuous** power (while *red* Main Disconnect Switch is ON) to accessories.
9. **To adjust alarm time**, for agitators and blowers follow the procedure below: (See Illustration 3)
  - a) Shut off machine.
  - b) Turn **off** *red* Main Disconnect Switch, loosen two screws on door, and open Main Control Panel lid.
  - c) Turn Timer Relay knob to desired setting. (clockwise to **increase** warning time)
  - d) Close lid, tighten two screws on door, turn machine on, turn on *red* Main Disconnect Switch and press *green* Start Button.
  - e) Retest machine

### Stopping Your Machine:

- 1) Switch the remote switch to “AIR ONLY” and wait until the hose is clear of all material.
- 2) Turn the control switch on the remote control cord to the “off” position and unplug the remote control cord from the panel.
- 3) Turn the disconnect to the “off” position.



#### **SAFETY NOTE:**

DO NOT FILL THE HOPPER TO CAPACITY AT THE END OF THE DAY. THE MATERIAL WILL COMPRESS AND CAN CAUSE MACHINE LOCKUP DURING THE FOLLOWING MORNING START-UP.

---

### Mechanical Settings:

The controls of your machine contain the blower and slidegate controls to adjust your machine for each application and type of insulation. (See illustration 4 on page 14.) **Blower control** (air) and **slidegate** (material feed) are adjusted according to:

|                     |  |
|---------------------|--|
| TYPE OF MATERIAL:   | Cellulose and fiberglass have different textures and densities that respond to machine settings.                             |
| HOSE:               | Corrugations or roughness of interior surface, diameter, length and elevation of hose will also require varying adjustments. |
| WEATHER CONDITIONS: | Temperature and humidity may require day to day adjustment of machine settings.  |

### Blower Control and Slidegate General Settings:

Blower control can increase or decrease the amount of air in the system, affecting the velocity (speed) and spread rate (coverage) of insulation. (See illustration 4 on page 14.) The blower control valve is used for controlling air pressure and amount of air flow.

Opening or closing slidegate (material feed) controls the amount of insulation dropping into the airlock which changes the production rate (lbs. per hour). (See illustration 4 on page 14.) For calibration purposes the scale located on the machine indicates how many inches the airlock slidegate is opened.



The blower and slidegate controls **working together** affect the distance insulation can be blown through a hose without plugging. These controls also affect the accurate blowing of insulation for spraying applications.

These settings control the following:

- **Density** of insulation blown in application.
- **Velocity** of material impact when spraying.
- **Dust** on open blow.
- Material **spread rate** or coverage.
- **Production** rate (lbs. per hour blown).

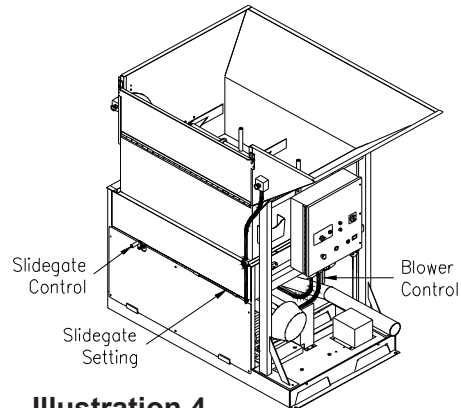

**Illustration 4**

### **General Blower Control and Slidegate Settings for Open Blow:**

With the **slidegate** closed and blower control valve on low (valve open), turn **agitator-feed and blower on**. Fill hopper with insulation and adjust **blower valve** and **slidegate**. Move controls proportional to each other. (i.e. If **blower valve** is half open, **slidegate** should be half open.) As hose length is increased, air pressure/volume is increased by closing off the **blower valve** while closing the slidegate proportionally. This will increase the distance insulation can be blown through the hose, while decreasing the blowing production rate (lbs. per hour blown). (See illustration 4)

### **Shredder Assembly:**

This unit is supplied with a shredder assembly; airlock/agitator speeds are preset at the factory. **No** further sprocket setting speeds are needed, as this system will accommodate most insulations and applications. However, the shredder and agitator **direction** can be adjusted as described below.

### **Shredder & Agitator Adjustment:**

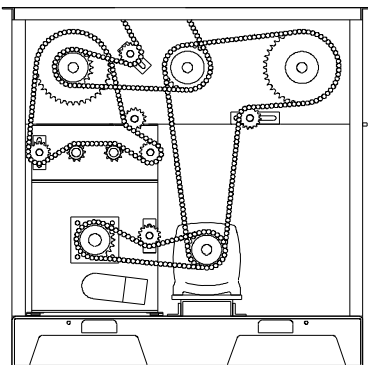

**Illustration 5**

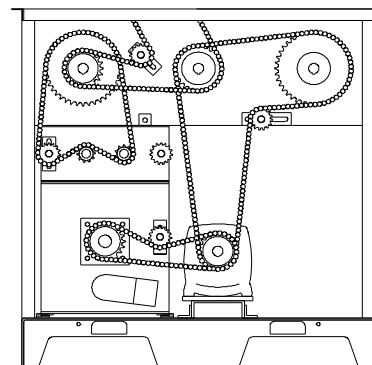

**Illustration 6**

**Unidirectional Rotation** (See illustration 5) is preferred as an all-around setting for a combination of materials and applications. This setting provides the greatest **coverage** and **best control** for internal wetting (stabilized) and open blow applications.

**Center-Down Rotation** (See illustration 6) force feeds the insulation into the airlock at a faster rate. This direction provides the greatest **production** for cellulose insulation in an open attic blow application although coverage may decrease.

**GENERAL MAINTENANCE**

Your Krendl Model #5200-3E Machine is designed to be used with minimal maintenance for all its components. The following is only a guide; experience is the best guide for the right maintenance schedule for you.

| DESCRIPTION   | EACH SHIFT | 40 HOURS | 200 HOURS | 1000 HOURS |
|---|------------|----------|-----------|------------|
| CHECK GUARDS  | X          |          |           |            |
| CHECK DRIVE ALIGNMENT & TENSION   | X          |          |           |            |
| CLEAN BLOWER AIR FILTER   |            | X        |           |            |
| CHECK BLOWER OIL LEVEL  |            | X        |           |            |
| GREASE BLOWER BEARINGS  |            |          | X         |            |
| LUBRICATE DRIVE CHAINS WITH A DRY LUBRICANT   |            |          | X         |            |
| GREASE SHREDDER, AIRLOCK, & AGITATOR BEARINGS   |            |          | X         |            |
| CHANGE BLOWER OIL<br>(needs to be changed after first 100 hours of operation and thereafter every 1000 hours) |            |          |           | X          |

**NOTE:** When further maintenance is needed, please refer back to other manufacturer's manuals for additional assistance!

**SAFETY NOTE****WHEN MAINTENANCE IS TO BE PERFORMED ON THE MACHINE ALWAYS:**

- 1) TURN THE MAIN DISCONNECT SWITCH TO THE OFF POSITION .
- 2) UNPLUG THE REMOTE CORD FROM THE RECEPTACLE.

**RECOMMENDED LUBRICATION**

|                  |  |
|------------------|--|
| ALL BEARINGS:    | GREASE: TRITON 460 or MOBILITH SHC 460 (NLGI grade #1.5)   |
| DRIVE CHAIN:     | DRY LUBRICANT (EG: DRY GRAPHITE)   |
| BLOWER:          | OIL: MD ONE (Refer to blower manual)<br>GREASE: TRITON 460 or MOBILITH SHC 460 (NLGI grade #1.5) |
| AIRLOCK REDUCER: | OIL: KLUBERSYNTH UH1 6-460   |

**Bearing Grease Zerks**

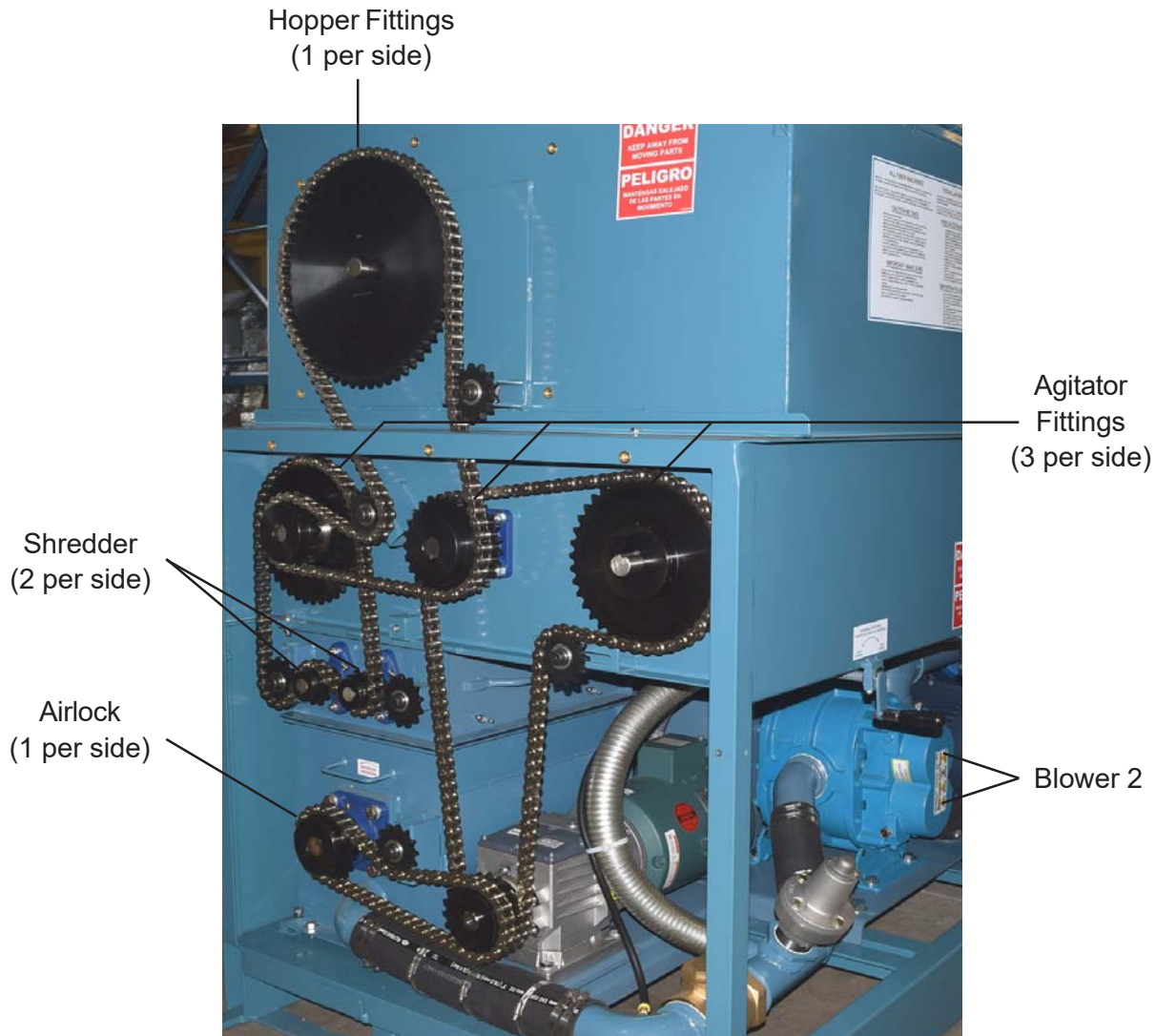

## Airlock: (Seal Replacement)

The purpose of the airlock seal is to trap air and insulation until it rotates 180° to the 6:00 o'clock position. At this point, insulation is pushed by air from the blower, out of the chamber. Worn or damaged seals allow air and insulation to escape back into hopper, thus reducing production and coverage. When it is necessary to replace seals, follow these directions:

Remove chain and air hoses from both input and output of airlock. Using a 5/8" socket, remove hold down bolts from airlock. Lower the front of the airlock down by loosening the jamb nuts and turning the lift bolts counter clockwise. Slide the airlock out of the machine. (See illustration 7) Airlock rotor plates that are damaged (bent) will need replaced. (Refer to Rotor Plate Replacement below.) Take out rubber seal by removing seven plate fastening bolts and nuts and top plate. The base plate will remain attached to airlock shaft. To install a new seal, reverse procedure. Seal should be inserted tight against the back base plate, pressing the lower tabs of the seal down under the adjacent seal with a flat blade screwdriver. Make sure all bolt holes are aligned while each side of seal is equally pressed against the end plates, before tightening bolts. Seal should be bent forwards for **counter clockwise** rotation. (See illustration 9)

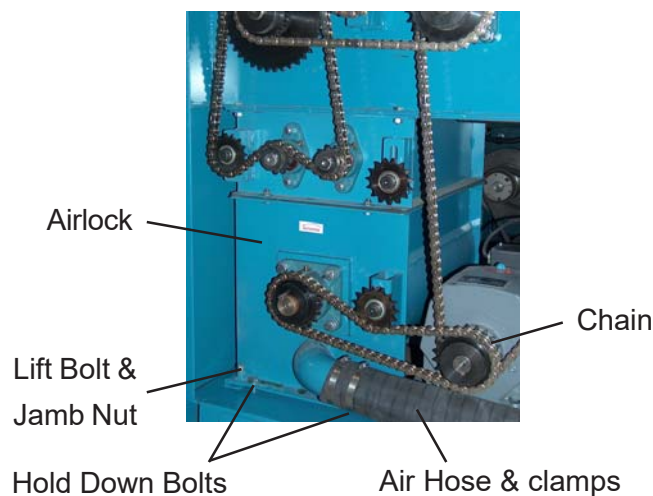

Illustration 7

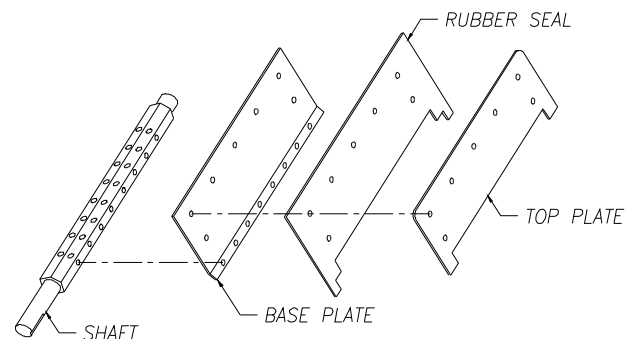

Illustration 8

## Base Plate Replacement:

1. Remove damaged baseplate assembly from shaft using ratchet drive wrench with extension and 9/16" socket.
2. Check seal for wear and damage. (Installing seal and top plate on the bench is quick and easy). Remove bolts from plate assembly and replace with new seal. Make sure seal and top plate are assembled on **correct** side of base plate before assembling in airlock. Seal should press backward towards top plate when installed correctly into airlock chamber. (Illustration 9)
3. Install the rotor plate assembly into the airlock. The airlock runs **counter clockwise** viewing it from the sprocket drive shaft. (Illustration 9) Align the base plate with holes on airlock shaft using a tapered punch. **Caution:** Do not mount rotor plate backwards. If installed

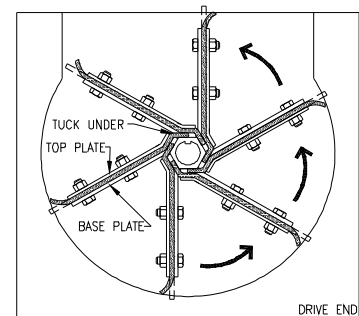

Illustration 9

(Note: Entire rotor plate assembly may be removed and replaced. This procedure maybe easier than replacing just the seals.)

improperly, damage to seals will result and put undue stress on agitator motor. This causes overheating and poor production. Seal should be bent backward to allow for a **clockwise** rotation of rotor.

5. As rotor plate is installed, press bottom tab of seal under adjacent seal with flat blade screwdriver. (See illustration 9 on page 17)

### **Chain:** (Adjustment) (#60 Nickel Plated)

A smooth operating chain drive should have a slight sag on the idler side of the chain. New chains should be installed under slight tension as they will elongate a small amount due to seating of pins and bushings during the first few days of operation. Chain should be kept in good condition by proper lubrication (use dry film lubricant Dow 321) and occasional cleaning. Soaking chain in container of 10 weight oil will provide for internal lubrication of pins and bushings. However, excess oil must be drained and wiped away as excessive lubrication will cause insulation accumulation on chain. Worn out chain should be replaced. When chain is replaced, worn sprockets should also be replaced, preventing further damage to new chain.

### **Sprockets:**

**Check Sprockets For Wear.** Misalignment and/or loose sprockets and improper chain tension causes the premature wear of chain and sprockets. All sprockets, except speed reducer and idler sprockets, have been secured with a medium grade Loctite (general purpose thread locker), to prevent gradual movement. The set screws and key are also inserted with a medium grade Loctite. If sprocket is difficult to remove, it may be heated with a propane torch to loosen.



**Caution:** Do not overheat sprocket or damage to bearing will result. A pulley or bearing puller can then be used to remove the sprocket and key. Replace new sprocket on shaft with key and medium grade Loctite applied to shaft. Align sprocket with corresponding sprocket, using a straightedge placed along face of teeth and tighten set screws.

### **Bearings:**

Agitator Bearings in hopper are double-sealed, self aligning ball bearings. They have grease fittings and should be periodically lubricated. At least every 3 months. If bearings produce noise or heat (*too-hot-to-touch*), the bearings should be replaced.

### **Agitator Bearing Replacement:**

Spray area with rust penetrant (WD-40). Remove sprocket (See SPROCKET section above). Remove the four bolts from bearing flange. Loosen set screws on bearing hub at each end of agitator shaft. Since all set screws are installed with a medium grade Loctite, a propane torch may be used to assist in removing them. Do not overheat unit, causing shaft to expand. Using a rubber mallet, drive agitator shaft an inch in one direction, creating a space between hopper and bearing unit. A bearing puller can then be used to remove the bearing. Eliminate any metal burrs from shaft with file and install new bearings with felt seals. Use a medium grade Loctite on set screws before securing bearing to shaft. (Check shaft diameter before ordering bearings)



**ELECTRICAL SYSTEM**

**ELECTRICAL DIAGRAM:** Periodically, disconnect machine from power source and check all electrical connections and components for broken or loose wires, disconnect machine from power source and check all electrical connections and components for broken or loose wires, disconnect machine from power source and check all electrical connections and components for broken or loose wires. Machine Vibration can cause fasteners to loosen.

**MODEL #5200-3E-240  
240 Volt 3-Phase**

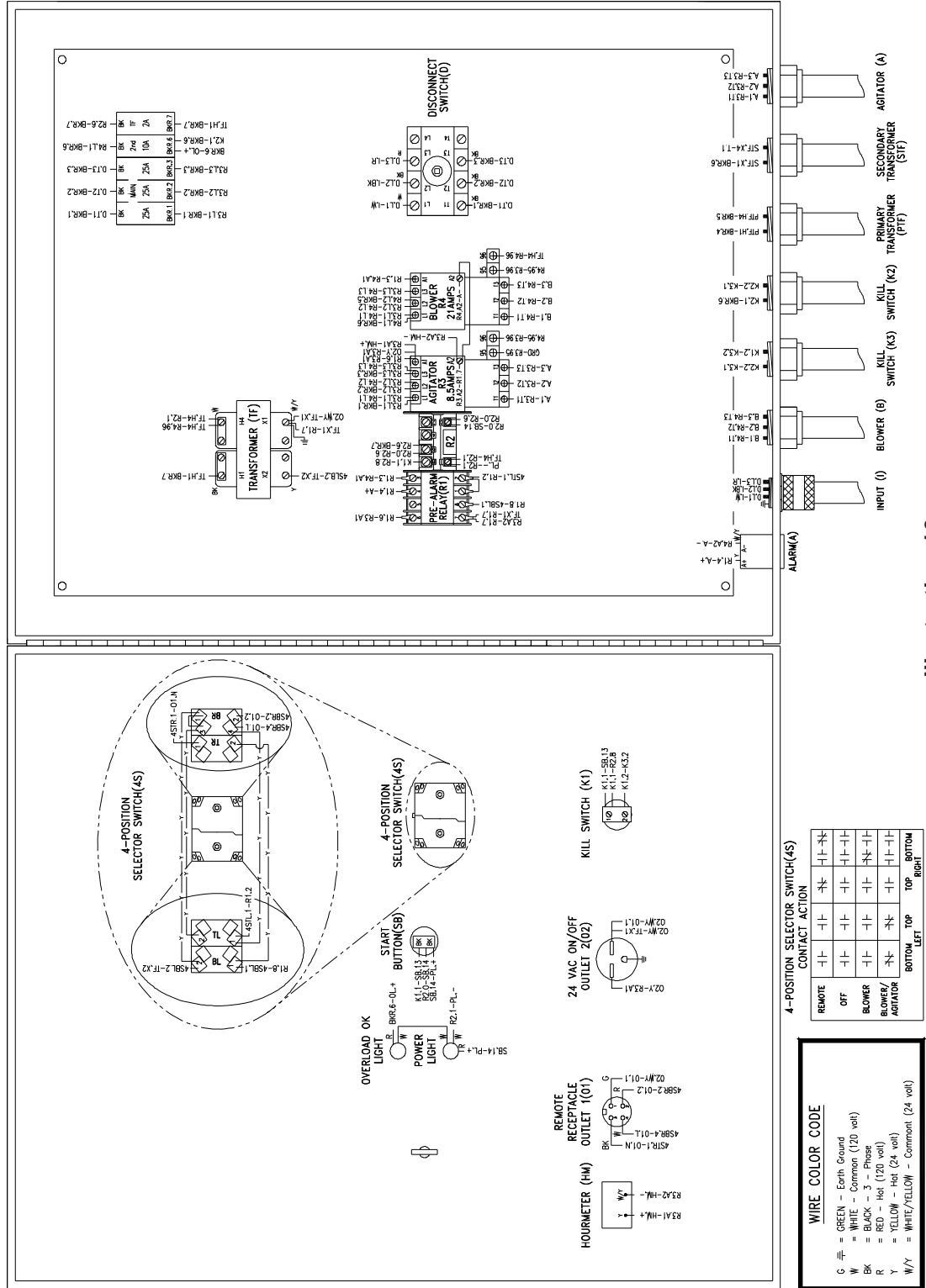

**Illustration 10**

**WIRE COLOR CODE**

- G = GREEN - Earth Ground
- W = WHITE - Common (120 volt)
- Bk = BLACK - 3 Phase Power
- R = RED - Hot (120 volt)
- Y = YELLOW - Hot (24 volt)
- W/Y = WHITE/YELLOW - Common (24 volt)

| CONTACT ACTION                  | TOP LEFT |     | TOP RIGHT |          |
|---------------------------------|----------|-----|-----------|----------|
|                                 | REMOTE   | OFF | BLOWER    | AGITATOR |
| 4-POSITION SELECTOR SWITCH (AS) | +        | +   | +         | +        |

## TROUBLESHOOTING

### WARRANTY

This unit is backed by a warranty for manufacturer's defects. If your machine needs service during the warranty time period, call your supplier immediately. DO NOT attempt to service the machine, as this voids the warranty!

### IMPORTANT

At any signs of trouble with your machine, stop immediately, disconnect power and call your supplier. Refer to the GENERAL MAINTENANCE section of this manual for further details. Always disconnect the electrical power before making any inspections or repairs.

## TROUBLESHOOTING

### PROBLEM

- 1.) Insufficient air

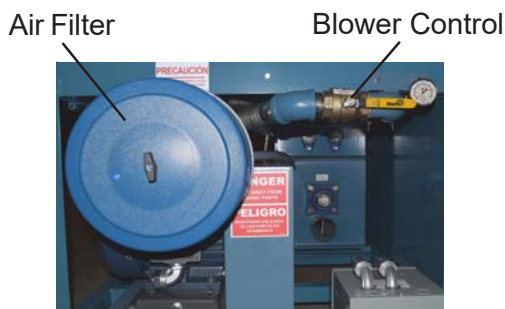

**Illustration 11**



**Illustration 12**

- 2.) No material flow

### CORRECTIVE ACTION

- A. Check that the blower control valve isn't fully open. Close or adjust the handle control as needed. You should be able to get over 4 p.s.i. of air on gauge. See illustration 11.
  - B. Check that the blower relief valve is not stuck closed. See illustration 12.
  - C. Check if blower air filter and intake hose is clogged. See illustration 11.
  - D. Check airstream and bypass air hose connections, clamps, etc.
  - E. Check that the one way air check valve isn't stuck open. See illustration 12
  - F. Check belts, adjust /replace as required and check for missing keys under drive pulleys.
  - G. Insulation hose plugged. Make sure the air bypass valve is completely closed, then switch machine to blower only to blow out the hose. If problems still occur, try hitting the hose where it is plugged to release the material.
  - H. If the airlock seals and/or airlock components are worn or damaged, replace all the parts as needed.
- A. Check material level in main hopper.
  - B. If the material slidegate is closed or adjusted in too far for material feed rate, open the slidegate.
  - C. Check the belts, and adjust or replace them as required. Check for missing keys under the drive pulleys.



- D. Check chains, adjust or replace as required.  
Check for missing keys under drive sprockets.
- E. Insulation hose plugged. Make sure the air bypass valve is completely closed, then switch machine to blower only to blow out the hose. If problems still occur, try hitting the hose where it is plugged to release the material.

## SPARE PARTS LIST

The following is a recommended spare parts list. To keep your machine up and running, these are the parts we suggest you keep on hand for your Model #5200-3E Krendl Machine.

| PART #        | DESCRIPTION                 | QUANTITY |
|---------------|-----------------------------|----------|
| 250503-8      | AGITATOR BEARINGS           | 8        |
| 250503-7      | AGITATOR BEARING FELT SEALS | 8        |
| 8036-2        | SHREDDER BEARINGS           | 4        |
| 517-7         | SHREDDER BEARING FELT SEALS | 4        |
| 8065-2        | AIRLOCK BEARINGS            | 2        |
| 8065-3        | AIRLOCK BEARING FELT SEALS  | 2        |
| 250300-21     | V-BELT MOTOR TO BLOWER      | 1        |
| 5200-9M-2PLYF | AIRLOCK SEALS               | 6        |
| ML-60NP       | #60 MASTER LINK             | 6        |
| 81-1063       | FILTER                      | 1        |

**PARTS LIST**

**#5200-3E Exploded Parts View**

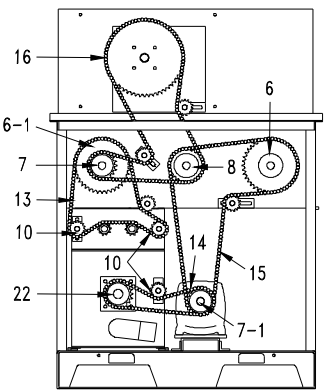
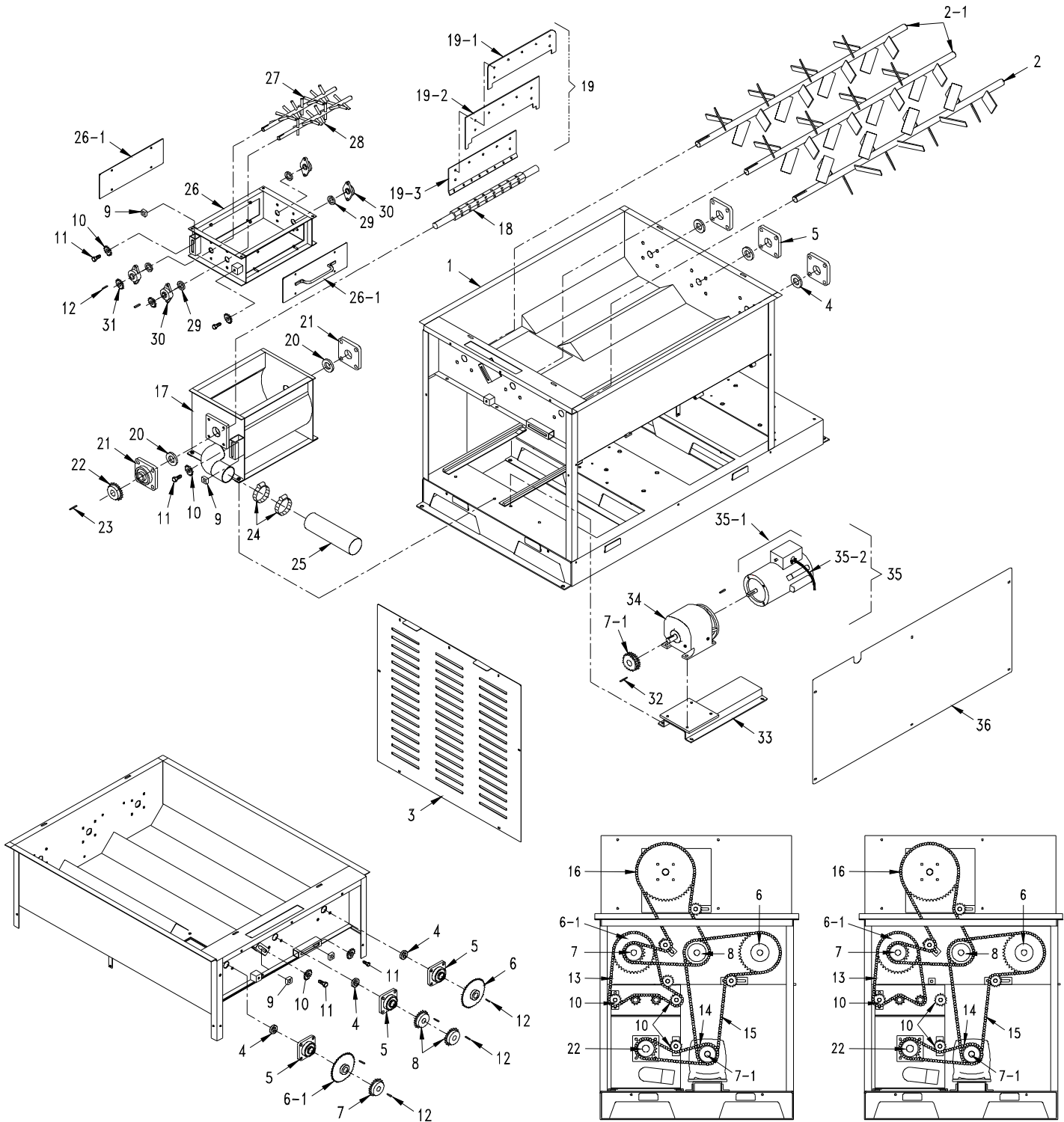

**Unidirectional**

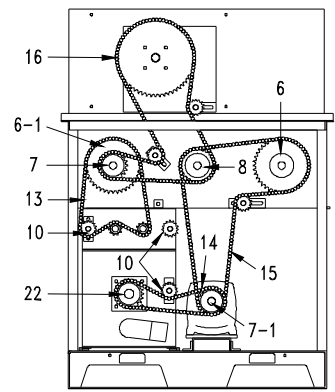

**Center - Down**

**#5200-3E-240 Exploded Parts View**

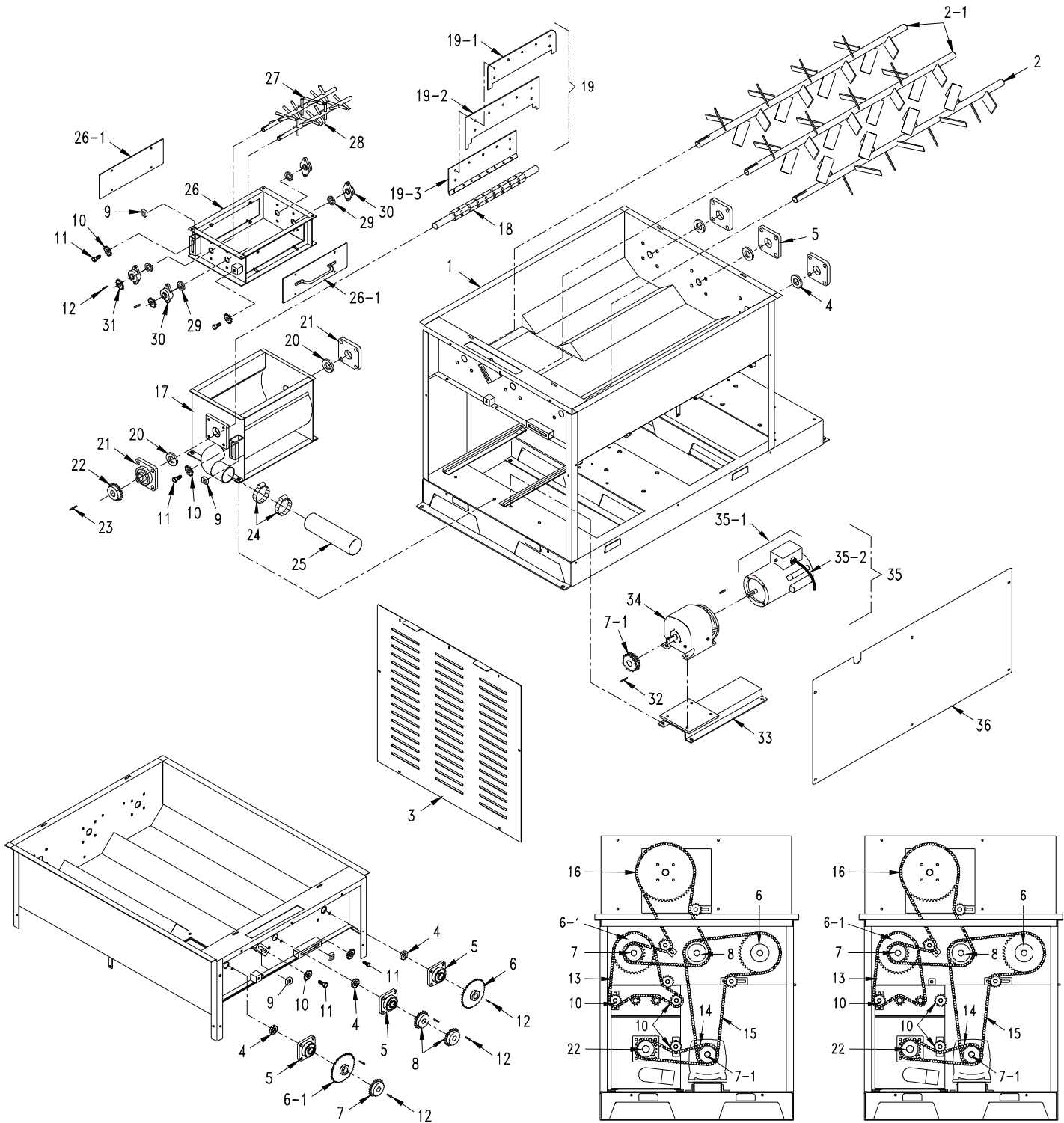

**#5200-3E Exploded Parts View**

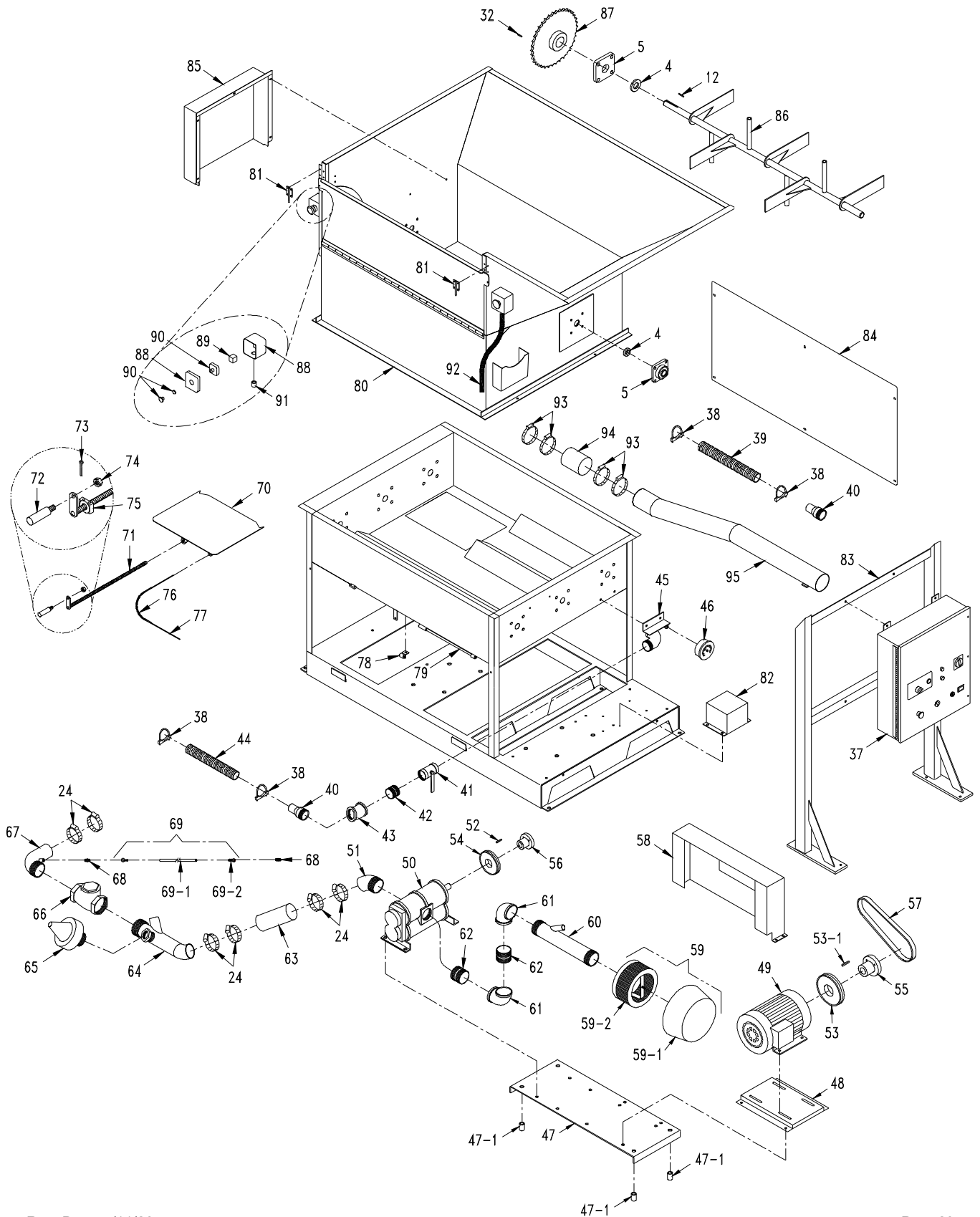

**#5200-3E-240 Exploded Parts View**

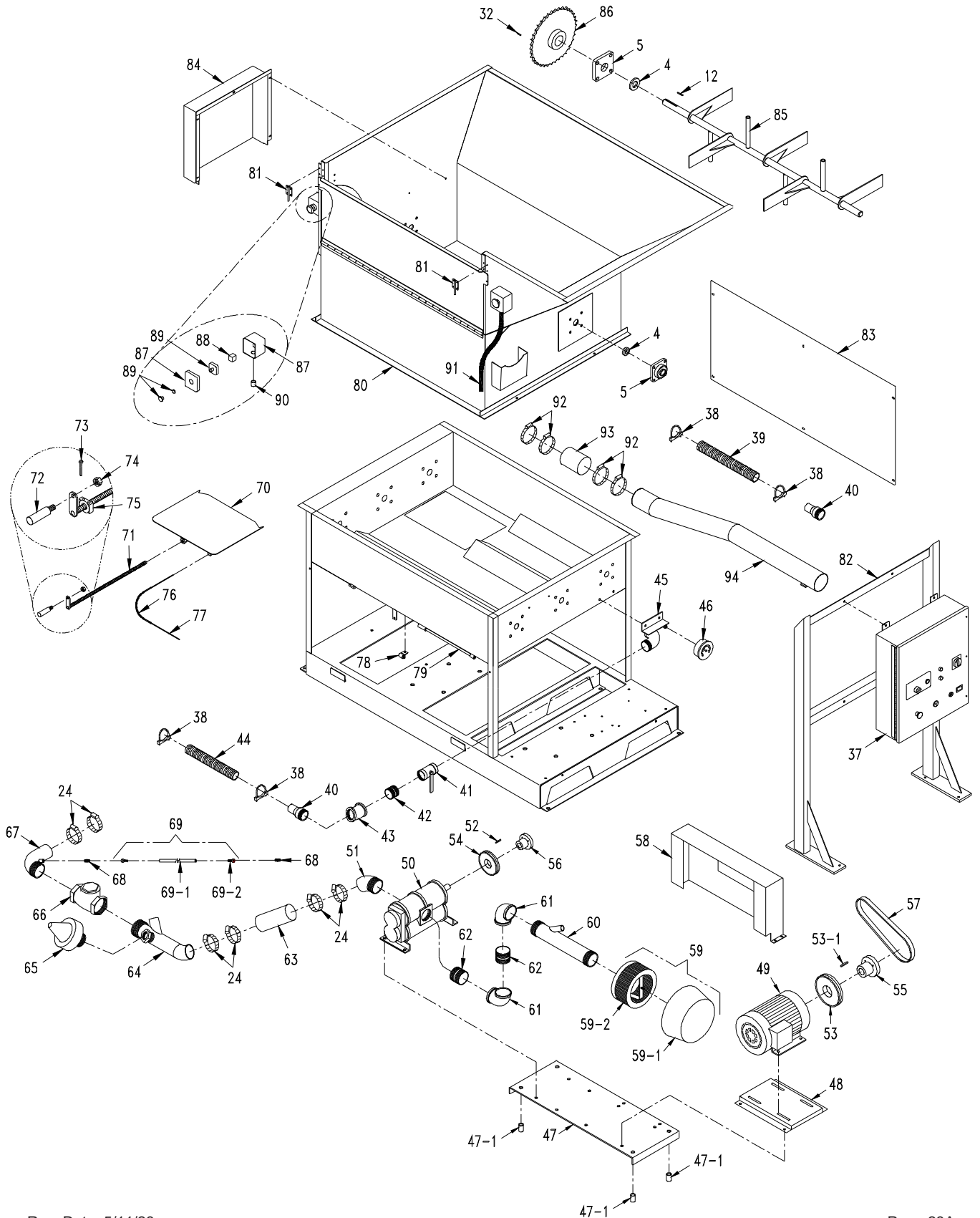

**#5200-3E Exploded Parts List**

| <b>Item#</b> | <b>Part#</b>   | <b>Description</b>                         |
|--------------|----------------|--|
| 1            | 5200-1E-1      | Base, (Upper & Lower Portion)              |
| 2            | 4000-15        | Agitator, Hopper, 16 Tine                  |
| 2-1          | 4000-29        | Agitator, Middle & Shredder, 17 Tine (2)   |
| 3            | 5200-47-1-R2   | Guard, Chain                               |
| 4            | 250503-7       | Seal, Felt, 1 1/4" (8)                     |
| 5            | 250503-8       | Bearing, Flange, 4-Bolt, 1 1/4" (8)        |
| 6            | S-H60B40F-1.25 | Sprocket, #60 40T x 1 1/4"HT               |
| 6-1          | 5200-121       | Sprocket, #60 40T x 1 1/4"HT (Turned Down) |
| 7            | S-H60B20F-1.25 | Sprocket, #60 20T x 1 1/4"                 |
| 7-1          | 5200-122       | Sprocket, #60 20T x 20T x 1 1/4"           |
| 8            | S-H60B25F-1.25 | Sprocket, #60 25T x 1 1/4" (2)             |
| 9            | 40052          | Nut, 1" x 1" x 1/2" (Plated) (5)           |
| 10           | 60BB13H        | Sprocket #60, Idler, 13HT x 5/8" (7)       |
| 11           | FSB120         | 5/8" x 3/4" Shoulder Bolt (2)              |
| 11           | FSB092         | 5/8" x 1" Shoulder Bolt (4)                |
| 12           | 562Z           | 1/4" x 1/4" x 1 1/4" Key (7)               |
| 13           | 60NP-51        | Chain, #50 x 51" Long (Center Down)        |
| 13           | 60NP-55        | Chain, #50 x 55" Long (Unidirectional)     |
| 14           | 60NP-40.5      | Chain, #50 x 40 1/2" Long                  |
| 15           | 60NP-88.5      | Chain, #50 x 88 1/2" Long                  |
| 16           | 60NP-92.5      | Chain, #60 x 92 1/2" Long                  |
| 17           | 5200-5-R1      | Chamber, Airlock, 5200                     |
| 18           | 5200-6         | Shaft, Airlock, 5200                       |
| 19           | 5200-9-ASSY    | Seal Assy, 5200, 18" (2 PLY/FAB)           |
| 19-1         | 5200-7         | Plate, Top, Airlock                        |
| 19-2         | 5200-9M-2PLYF  | Seal, Airlock                              |
| 19-3         | 5200-8         | Plate, Bottom, Airlock                     |
| 20           | 8065-3         | Felt Seal, 1 1/2" (2)                      |
| 21           | 8065-2         | Bearing, 4-Bolt, 1 1/2" (2)                |
| 22           | S-H60BS20-1.5  | Sprocket, #60 20T x 1 1/2"                 |
| 23           | 556            | 3/8" Square Stock, 1 1/4" Long             |
| 24           | 339A           | Clamp, Hose, 3" (8)                        |
| 25           | RM-OTH095-MI   | Hose, Radiator, 3" x 16"                   |
| 26           | 5200-10-R1     | Shredder Box                               |
| 26-1         | 5200-129       | Access Cover, Shredder Box (2)             |
| 27           | 5200-11-A      | Shredder Agt., Short (18 Tine)             |
| 28           | 5200-11-B      | Shredder Agt., Long (20 Tine)              |
| 29           | 517-7          | Seal, Felt Airlock 1" Bore (4)             |
| 30           | 8036-2         | Bearing, 2-Bolt, 1" (4)                    |
| 31           | S-H60B11F-1    | Sprocket, #60, 11T x 1" (2)                |
| 32           | 150311Z        | Key, 1/4" x 1/4" x 1 3/4" (2)              |

**#5200-3E-240 Exploded Parts List**

| <b>Item#</b> | <b>Part#</b>   | <b>Description</b>                         |
|--------------|----------------|--|
| 1            | 5200-1E-1      | Base, (Upper & Lower Portion)              |
| 2            | 4000-15        | Agitator, Hopper, 16 Tine                  |
| 2-1          | 4000-29        | Agitator, Middle & Shredder, 17 Tine (2)   |
| 3            | 5200-47-1-R2   | Guard, Chain                               |
| 4            | 250503-7       | Seal, Felt, 1 1/4" (8)                     |
| 5            | 250503-8       | Bearing, Flange, 4-Bolt, 1 1/4" (8)        |
| 6            | S-H60B40F-1.25 | Sprocket, #60 40T x 1 1/4"HT               |
| 6-1          | 5200-121       | Sprocket, #60 40T x 1 1/4"HT (Turned Down) |
| 7            | S-H60B20F-1.25 | Sprocket, #60 20T x 1 1/4"                 |
| 7-1          | 5200-122       | Sprocket, #60 20T x 20T x 1 1/4"           |
| 8            | S-H60B25F-1.25 | Sprocket, #60 25T x 1 1/4" (2)             |
| 9            | 40052          | Nut, 1" x 1" x 1/2" (Plated) (5)           |
| 10           | 60BB13H        | Sprocket #60, Idler, 13HT x 5/8" (7)       |
| 11           | FSB120         | 5/8" x 3/4" Shoulder Bolt (2)              |
| 11           | FSB092         | 5/8" x 1" Shoulder Bolt (4)                |
| 12           | 562Z           | 1/4" x 1/4" x 1 1/4" Key (7)               |
| 13           | 60NP-51        | Chain, #50 x 51" Long (Center Down)        |
| 13           | 60NP-55        | Chain, #50 x 55" Long (Unidirectional)     |
| 14           | 60NP-40.5      | Chain, #50 x 40 1/2" Long                  |
| 15           | 60NP-88.5      | Chain, #50 x 88 1/2" Long                  |
| 16           | 60NP-92.5      | Chain, #60 x 92 1/2" Long                  |
| 17           | 5200-5-R1      | Chamber, Airlock, 5200                     |
| 18           | 5200-6         | Shaft, Airlock, 5200                       |
| 19           | 5200-9-ASSY    | Seal Assy, 5200, 18" (2 PLY/FAB)           |
| 19-1         | 5200-7         | Plate, Top, Airlock                        |
| 19-2         | 5200-9M-2PLYF  | Seal, Airlock                              |
| 19-3         | 5200-8         | Plate, Bottom, Airlock                     |
| 20           | 8065-3         | Felt Seal, 1 1/2" (2)                      |
| 21           | 8065-2         | Bearing, 4-Bolt, 1 1/2" (2)                |
| 22           | S-H60BS20-1.5  | Sprocket, #60 20T x 1 1/2"                 |
| 23           | 556            | 3/8" Square Stock, 1 1/4" Long             |
| 24           | 339A           | Clamp, Hose, 3" (8)                        |
| 25           | RM-OTH095-MI   | Hose, Radiator, 3" x 16"                   |
| 26           | 5200-10-R1     | Shredder Box                               |
| 26-1         | 5200-129       | Access Cover, Shredder Box (2)             |
| 27           | 5200-11-A      | Shredder Agt., Short (18 Tine)             |
| 28           | 5200-11-B      | Shredder Agt., Long (20 Tine)              |
| 29           | 517-7          | Seal, Felt Airlock 1" Bore (4)             |
| 30           | 8036-2         | Bearing, 2-Bolt, 1" (4)                    |
| 31           | S-H60B11F-1    | Sprocket, #60, 11T x 1" (2)                |
| 32           | 150311Z        | Key, 1/4" x 1/4" x 1 3/4" (2)              |

**#5200-3E Exploded Parts List**

| <b>Item#</b> | <b>Part#</b> | <b>Description</b>                                  |
|--------------|--------------|---|
| 33           | 5200-3E-2    | Mount, Reducer                                      |
| 34           | 250529-A     | Reducer, 2 H.P.                                     |
| 35           | 2502007-A    | Motor Assy, 3 H.P. 3-Phase                          |
| 35-1         | 2502007      | Motor 3 H.P. 3-Phase                                |
| 35-2         | 543-M-75     | Cord Conduit 1/2" (3 feet)                          |
| 36           | 5200-48-R1   | Guard, Side (Crankrod Side)                         |
| 37           | 5200-3E-1    | Panel Box Assy                                      |
| 38           | 5200-106     | Muffler Clamp (4)                                   |
| 39           | RM-OTH103-MI | Pipe, Exhaust Flex (58")                            |
| 40           | 5200-81      | Adapter, 2" Barb (2)                                |
| 41           | 8051         | Ball Valve, 2"                                      |
| 42           | 5200-81-1    | Nipple, 2" Close Black Pipe                         |
| 43           | 250340-2     | Elbow, 2" 45 Degree Black Pipe                      |
| 44           | RM-OTH103-MI | Pipe, Exhaust Flex (12")                            |
| 45           | 5200-1E-2    | Pressure Guage Bracket                              |
| 46           | 5200-59      | Guage, Pressure, 0-10 PSI                           |
| 47           | 250300-17    | Mount, Base, Positive Pressure Blower System        |
| 47-1         | 5200-1E-11   | Spacer, 1 1/2" Long (4)                             |
| 48           | 200300-2     | Mount, Motor  |
| 49           | 200300-1     | Motor 7.5 H.P., 3-Phase                             |
| 50           | 250300-1     | Blower, Rotary Positive Pressure Blower (4007)      |
| 51           | 5200-3E-3    | Elbow, 3" 45 Degree (w/3" Pipe Nipple)              |
| 52           | 449-R1       | Key, 3/16" x 3/16" x 1 7/8"                         |
| 53           | 250300-3     | Pulley, 2Q3V80                                      |
| 53-1         | --           | Key, 5/16" x 5/16" x 2 3/8"                         |
| 54           | 250300-4     | Pulley, 2Q3V69                                      |
| 55           | 250300-5     | Bushing, Q1 1 3/8"                                  |
| 56           | 250300-6     | Bushing, Q1 7/8"                                    |
| 57           | 250300-21    | 2V-Belt, 56" (2/3VX560)                             |
| 58           | 5200-3E-6    | Guard, Belt   |
| 59           | 250300-2-R1  | Silencer Assy., Intake Filter (Blue) (After 5/7/01) |
| 59-1         | --           | Cover, Filter                                       |
| 59-2         | 81-1063      | Filter for 250300-2-R1 (Blue)                       |
| 60           | 5200-3E-5    | Tube, 3" x 14" Long                                 |
| 61           | 5200-76      | Elbow, 3" 90 Degree Black Pipe (2)                  |
| 62           | 250300-11    | Nipple, 3" Close Black Pipe (2)                     |
| 63           | RM-OTH095-MI | Hose, Radiator, 3"                                  |
| 64           | 5200-3E-4    | Tube, Pressure Relief                               |
| 65           | 4200-12      | Pressure Relief Valve                               |
| 66           | 250539       | Check Valve, 3"                                     |
| 67           | 5200-66      | Elbow, Pressure Guage                               |
| 68           | IWS-32       | Male Connector (2)                                  |



**#5200-3E-240 Exploded Parts List**

| <b>Item#</b> | <b>Part#</b>     | <b>Description</b>                                  |
|--------------|------------------|---|
| 33           | 5200-3E-2        | Mount, Reducer                                      |
| 34           | 250529-A         | Reducer, 2 H.P.                                     |
| 35           | 2502007-208-A    | Motor Assy, 3 H.P. 3-Phase                          |
| 35-1         | 2502007          | Motor 3 H.P. 3-Phase                                |
| 35-2         | 543-M-75         | Cord Conduit 1/2" (3 feet)                          |
| 36           | 5200-48-R1       | Guard, Side (Crankrod Side)                         |
| 37           | 5200-3E-1-208    | Panel Box Assy, 208/240 Volt                        |
| 38           | 5200-106         | Muffler Clamp (4)                                   |
| 39           | RM-OTH103-MI     | Pipe, Exhaust Flex (58")                            |
| 40           | 5200-81          | Adapter, 2" Barb (2)                                |
| 41           | 8051             | Ball Valve, 2"                                      |
| 42           | 5200-81-1        | Nipple, 2" Close Black Pipe                         |
| 43           | 250340-2         | Elbow, 2" 45 Degree Black Pipe                      |
| 44           | RM-OTH103-MI     | Pipe, Exhaust Flex (12")                            |
| 45           | 5200-1E-2        | Pressure Guage Bracket                              |
| 46           | 5200-59          | Guage, Pressure, 0-10 PSI                           |
| 47           | 250300-17        | Mount, Base, Positive Pressure Blower System        |
| 47-1         | 5200-1E-11       | Spacer, 1 1/2" Long (4)                             |
| 48           | 200300-2         | Mount, Motor  |
| 49           | 200300-1-208/240 | Motor 7.5 H.P., 3-Phase                             |
| 50           | 250300-1         | Blower, Rotary Positive Pressure Blower (4007)      |
| 51           | 5200-3E-3        | Elbow, 3" 45 Degree (w/3" Pipe Nipple)              |
| 52           | 449-R1           | Key, 3/16" x 3/16" x 1 7/8"                         |
| 53           | 250300-3         | Pulley, 2Q3V80                                      |
| 53-1         | --               | Key, 5/16" x 5/16" x 2 3/8"                         |
| 54           | 250300-4         | Pulley, 2Q3V69                                      |
| 55           | 250300-5         | Bushing, Q1 1 3/8"                                  |
| 56           | 250300-6         | Bushing, Q1 7/8"                                    |
| 57           | 250300-21        | 2V-Belt, 56" (2/3VX560)                             |
| 58           | 5200-3E-6        | Guard, Belt   |
| 59           | 250300-2-R1      | Silencer Assy., Intake Filter (Blue) (After 5/7/01) |
| 59-1         | --               | Cover, Filter                                       |
| 59-2         | 81-1063          | Filter for 250300-2-R1 (Blue)                       |
| 60           | 5200-3E-5        | Tube, 3" x 14" Long                                 |
| 61           | 5200-76          | Elbow, 3" 90 Degree Black Pipe (2)                  |
| 62           | 250300-11        | Nipple, 3" Close Black Pipe (2)                     |
| 63           | RM-OTH095-MI     | Hose, Radiator, 3"                                  |
| 64           | 5200-3E-4        | Tube, Pressure Relief                               |
| 65           | 4200-12          | Pressure Relief Valve                               |
| 66           | 250539           | Check Valve, 3"                                     |
| 67           | 5200-66          | Elbow, Pressure Guage                               |
| 68           | IWS-32           | Male Connector (2)                                  |

**#5200-3E Exploded Parts List**

| <b>Item#</b> | <b>Part#</b>    | <b>Description</b>                     |
|--------------|-----------------|--|
| 69           | IWS-25A         | Water Line, 1/4" x 6' w/swivel         |
| 69-1         | IWS-H-1/4       | 1/4" Hose                              |
| 69-2         | IWS-29          | Swivel, SAE 37 (2)                     |
| 70           | 5200-45         | Slidegate, 5200                        |
| 71           | 5200-46         | Crankrod w/ Handle Bracket             |
| 72           | 5200-60         | Handle                                 |
| 73           | FSB078          | Pin, Cotter, 1/8" x 1"                 |
| 74           | FN015           | N 3/8-16 Lock Nut-Crimped              |
| 75           | 5200-58         | Support, Crankrod                      |
| 76           | 5200-74         | Cover, Slidegate Cable 18 1/4"         |
| 77           | 5200-67         | Cable, Slidegate, Indicator, 33"       |
| 78           | 5200-69         | Mount, Indicator Cable                 |
| 79           | 5200-68         | Cover, Slidegate Indicator             |
| 80           | 5200-2-R5       | Hopper Extension, Flared, 5200         |
| 81           | 270700-2-13     | Barrel Slide (2)                       |
| 82           | 8130            | Transformer, 1.5 KVA                   |
| 83           | 5200-3E-8       | Electrical Stand                       |
| 84           | 5200-49-R1      | Guard, Side (Back Side)                |
| 85           | 5200-133        | Guard, Chain, Hopper                   |
| 86           | 5200-131-R2     | Hopper Agitator (Replaces 5200-131-R1) |
| 87           | S-H60B60F-1-1/4 | Sprocket,#60 60T x 1 1/4" Bore         |
| 88           | 8076            | Enclosure (2)                          |
| 89           | 8075-1          | Contact Block (2)                      |
| 90           | 508-2           | Killswitch (2)                         |
| 91           | 543-M-18        | Connector, Conduit, 1/2" Straight (2)  |
| 92           | 543-M-75        | Conduit, Flexible 1/2"                 |
| 93           | 340             | Clamp, Hose, 4" (4)                    |
| 94           | RM-OTH211-MI    | 4" Radiator Hose, 6" Long              |
| 95           | 5200-3E-10      | Tube, Output                           |
| 96           | 4000-12-R1      | Hose Bracket (Not Shown)               |
| 97           | ML-60NP         | Link Master #60 (6) (Not Shown)        |
| 98           | HL-60NP         | Link Half #60 (Not Shown)              |

**#5200-3E-240 Exploded Parts List**

| <b>Item#</b> | <b>Part#</b>    | <b>Description</b>                     |
|--------------|-----------------|--|
| 69           | IWS-25A         | Water Line, 1/4" x 6' w/swivel         |
| 69-1         | IWS-H-1/4       | 1/4" Hose                              |
| 69-2         | IWS-29          | Swivel, SAE 37 (2)                     |
| 70           | 5200-45         | Slidegate, 5200                        |
| 71           | 5200-46         | Crankrod w/ Handle Bracket             |
| 72           | 5200-60         | Handle                                 |
| 73           | FSB078          | Pin, Cotter, 1/8" x 1"                 |
| 74           | FN015           | N 3/8-16 Lock Nut-Crimped              |
| 75           | 5200-58         | Support, Crankrod                      |
| 76           | 5200-74         | Cover, Slidegate Cable 18 1/4"         |
| 77           | 5200-67         | Cable, Slidegate, Indicator, 33"       |
| 78           | 5200-69         | Mount, Indicator Cable                 |
| 79           | 5200-68         | Cover, Slidegate Indicator             |
| 80           | 5200-2-R5       | Hopper Extension, Flared, 5200         |
| 81           | 270700-2-13     | Barrel Slide (2)                       |
| 82           | 5200-3E-8       | Electrical Stand                       |
| 83           | 5200-49-R1      | Guard, Side (Back Side)                |
| 84           | 5200-133        | Guard, Chain, Hopper                   |
| 85           | 5200-131-R2     | Hopper Agitator (Replaces 5200-131-R1) |
| 86           | S-H60B60F-1-1/4 | Sprocket,#60 60T x 1 1/4" Bore         |
| 87           | 8076            | Enclosure (2)                          |
| 88           | 8075-1          | Contact Block (2)                      |
| 89           | 508-2           | Killswitch (2)                         |
| 90           | 543-M-18        | Connector, Conduit, 1/2" Straight (2)  |
| 91           | 543-M-75        | Conduit, Flexible 1/2"                 |
| 92           | 340             | Clamp, Hose, 4" (4)                    |
| 93           | RM-OTH211-MI    | 4" Radiator Hose, 6" Long              |
| 94           | 5200-3E-10      | Tube, Output                           |
| 95           | 4000-12-R1      | Hose Bracket (Not Shown)               |
| 96           | ML-60NP         | Link Master #60 (6) (Not Shown)        |
| 97           | HL-60NP         | Link Half #60 (Not Shown)              |

## 480Volt 3-Phase Electrical Exploded Parts View

### 480Volt 3-Phase

| Item # | Part #       | Description                                |
|--------|--------------|--|
| 37-1   | 5200-3E-7    | Box, Electrical                            |
| 37-2   | 5200-3E-1-6  | Plate, Backing                             |
| 37-3   | 132-B        | Receptacle, NEMA# 6-15R                    |
| 37-4   | 491          | Connector, 4 Pin Female (remote)           |
| 37-5   | KMC-069      | Decal, 24 Volt ON/OFF Outlet               |
| 37-6   | KMC-024      | Decal, Remote Control                      |
| 37-7   | 543-M-77     | Hour Meter                                 |
| 37-8   | 508-2        | Switch, Kill                               |
| 37-8-1 | 8075-1       | Contactor, Kill Switch (not shown)         |
| 37-9   | KMC-203      | Decal, Kill Switch                         |
| 37-10  | 600-R-01     | Disconnect Switch Assembly                 |
| 37-11  | 251080-2     | 12 Terminal Grounding Bar                  |
| 37-12  | 251080-35    | Amber Pilot Light 1/2" Neon                |
| 37-13  | 251080-36    | Green pilot Light 1/2" Neon                |
| 37-14  | 543-M-22     | Switch, 4-Position Selector                |
| 37-15  | 543-M-15     | Contact Block, (white) #KA-1 (not shown)   |
| 37-16  | 543-M-16     | Contact Block, (red) #KA-3 (not shown) (3) |
| 37-17  | KMC-068-R1   | Decal, (Remote/Manual - 4-Position)        |
| 37-18  | 543-M-59     | Switch, Pushbutton ON                      |
| 37-19  | KMC-UL       | Decal, Underwriters Laboratory             |
| 37-20  | RM-DINRAIL-A | Dinrail, 1 3/8"                            |
| 37-21  | 5200-3E-1-4  | Protector, Supply, 25 Amp, 3 Pole          |
| 37-22  | 5200-3E-1-5  | Protector, Supply, 5 Amp, 2 Pole           |
| 37-23  | 5200-3E-1-2  | Protector, Supply, 10 Amp, 1 Pole          |
| 37-24  | BRKR-2       | Breaker, 2 Amp                             |
| 37-25  | 1530-D       | Transformer, 4 Amp                         |
| 37-26  | 151080-49    | 1 3/8" Din Rail Clamp (6)                  |
| 37-27  | 543-M-41     | Socket, 8 Pin (2)                          |
| 37-28  | 543-M-39     | Relay f/Pre-Alarm System                   |
| 37-29  | 543-M-51     | Relay, Tubular 120V                        |
| 37-30  | 251080-22-R1 | Starter, 24V, 5HP                          |
| 37-31  | 251080-53-R1 | Starter, 10HP, 24V Coil                    |
| 37-32  | 251080-24-R1 | Thermal Overload, 4-6 Amp                  |
| 37-33  | 8021-15-R1   | Thermal Overload, 9-13 Amp                 |
| 37-34  | 151080-62    | Terminal Block, Large                      |
| 37-35  | 543-M-38     | Alarm for Pre-Alarm System, 24V            |
| 37-36  | 543-M-18     | Connector, Conduit, 1/2" Straight (5)      |
| 37-37  | 543-M-75     | Conduit, Flexible, 1/2"                    |
| 37-38  | 8021-6       | Connector, Cord, 3/4" Liquid Tite          |
| 37-39  | 8208         | Lock Nut, 3/4" Steel                       |
| 37-40  | 10-4 SO      | Wire, 10-4 SJ                              |
| 37-41  | 250321-1A-2  | Plug, 30Amp, 3 Phase                       |
| 37-42  | 251080-29    | Connector, Conduit, 1" Straight            |
| 37-43  | 251080-31    | Conduit, Flexible, 1"                      |

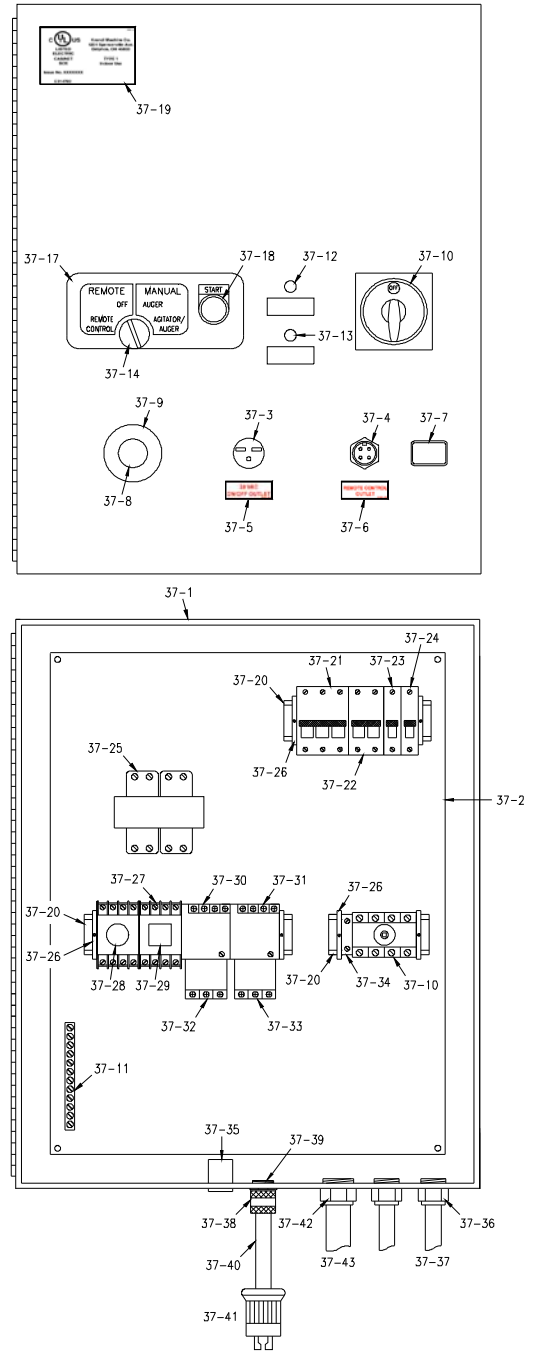

## 240Volt 3-Phase Electrical Exploded Parts View

### 480Volt 3-Phase

| Item # | Part #       | Description                                |
|--------|--------------|--|
| 37-1   | 5200-3E-7    | Box, Electrical                            |
| 37-2   | 5200-3E-1-6  | Plate, Backing                             |
| 37-3   | 132-B        | Receptacle, NEMA# 6-15R                    |
| 37-4   | 491          | Connector, 4 Pin Female (remote)           |
| 37-5   | KMC-069      | Decal, 24 Volt ON/OFF Outlet               |
| 37-6   | KMC-024      | Decal, Remote Control                      |
| 37-7   | 543-M-77     | Hour Meter                                 |
| 37-8   | 508-2        | Switch, Kill                               |
| 37-8-1 | 8075-1       | Contactor, Kill Switch (not shown)         |
| 37-9   | KMC-203      | Decal, Kill Switch                         |
| 37-10  | 600-R-01     | Disconnect Switch Assembly                 |
| 37-11  | 251080-2     | 12 Terminal Grounding Bar                  |
| 37-12  | 251080-35    | Amber Pilot Light 1/2" Neon                |
| 37-13  | 251080-36    | Green pilot Light 1/2" Neon                |
| 37-14  | 543-M-22     | Switch, 4-Position Selector                |
| 37-15  | 543-M-15     | Contact Block, (white) #KA-1 (not shown)   |
| 37-16  | 543-M-16     | Contact Block, (red) #KA-3 (not shown) (3) |
| 37-17  | KMC-068-R1   | Decal, (Remote/Manual - 4-Position)        |
| 37-18  | 543-M-59     | Switch, Pushbutton ON                      |
| 37-19  | KMC-UL       | Decal, Underwriters Laboratory             |
| 37-20  | RM-DINRAIL-A | Dinrail, 1 3/8"                            |
| 37-21  | 5200-3E-1-4  | Protector, Supply, 25 Amp, 3 Pole          |
| 37-22  | 5200-3E-1-2  | Protector, Supply, 10 Amp, 1 Pole          |
| 37-23  | BRKR-2       | Breaker, 2 Amp                             |
| 37-24  | 1530-D       | Transformer, 4 Amp                         |
| 37-25  | 151080-49    | 1 3/8" Din Rail Clamp (6)                  |
| 37-26  | 543-M-41     | Socket, 8 Pin                              |
| 37-27  | 543-M-39     | Relay f/Pre-Alarm System                   |
| 37-28  | ELU10-15     | 120V E-Mech Relay                          |
| 37-29  | ELU10-14     | Adapter, E-Mech Relay                      |
| 37-30  | 251080-53-R1 | Starter, 10HP, 24V Coil                    |
| 37-31  | 5200-3E-1-8  | Starter, Motor, 10HP, 24V                  |
| 37-32  | 5200-3E-1-9  | Thermal Overload, 7-10 Amp                 |
| 37-33  | 5200-3E-1-10 | Thermal Overload, 16-24 Amp                |
| 37-34  | 543-M-38     | Alarm for Pre-Alarm System, 24V            |
| 37-35  | 543-M-18     | Connector, Conduit, 1/2" Straight (5)      |
| 37-36  | 543-M-75     | Conduit, Flexible, 1/2"                    |
| 37-37  | 8021-6       | Connector, Cord, 3/4" Liquid Tite          |
| 37-38  | 8208         | Lock Nut, 3/4" Steel                       |
| 37-39  | 10-4 SO      | Wire, 10-4 SJ                              |
| 37-40  | 250321-1A-2  | Plug, 30Amp, 3 Phase                       |
| 37-41  | 251080-29    | Connector, Conduit, 1" Straight            |
| 37-42  | 251080-31    | Conduit, Flexible, 1"                      |

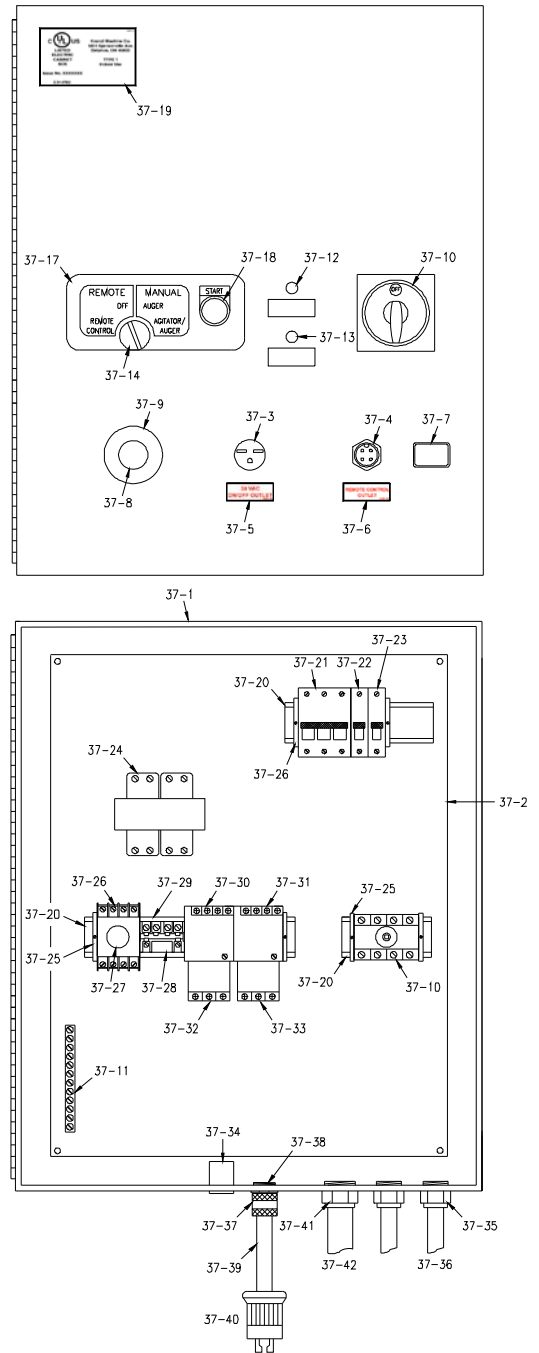

## GLOSSARY

|   |  |
|---|--|
| <b>BRIDGING</b>                           | A tendency for insulation to cling in the hopper forming an air pocket above the airlock. This hinders the normal feeding process of the machine.  |
| <b>CFM</b>                                | (Cubic feet per minute). A measurement of volume or <b>quantity</b> of air flowing at a certain rate, or air moving capability, of a blower. It is the volume of air moved per minute. Higher volume provides increased coverage and velocity of insulation as it leaves the hose.   |
| <b>CHECK VALVE</b>                        | A valve that allows air to flow in one direction only. When mounted on the outlet of the blower, it protects the blower from insulation contamination through the air hose when using one blower. When the blower stops, the valve closes.   |
| <b>COMMERCIAL SPRAY-ON</b>                | The application of insulation with adhesive to a surface which will remain exposed. The application must therefore be impacted in a smooth, uniform manner.  |
| <b>COVERAGE</b>                           | Refers to the amount of insulation coverage, usually measured in square feet, according to the R-value desired. This information is given on the insulation package.   |
| <b>NEW CONSTRUCTION WALL CAVITY SPRAY</b> | The spray application of insulation with water or adhesive into an exposed wall cavity to later be covered with drywall sheathing, etc.  |
| <b>PSI</b>                                | Pounds of pressure per square inch of <b>force</b> exerted on a surface by air or liquid. High-pressure blowers push the insulation through the hose. Higher pressure provides less hose plugging and increased compaction in side wall.   |
| <b>PRODUCTION RATE</b>                    | Pounds of insulation blown per hour.   |
| <b>RPM</b>                                | (Revolutions per minute). Speed at which the shaft of a rotating device (i.e. blower fan, agitator) is moving.   |
| <b>R-VALUE</b>                            | Resistance value. A precise measurement of the insulation's resistance to heat transfer. The higher the resistance value, the slower the heat will transfer through the insulating material.   |
| <b>RETRO-SIDEWALL</b>                     | This refers to the installation of insulation into an unexposed wall cavity. Insulation is usually installed through holes drilled into the exterior siding.   |
| <b>SETTLED DENSITY</b>                    | The point at which the insulation will not continue to settle further. Any insulation blown will have a certain amount of progressive settling that occurs over a period of time. Following the insulation manufacturer's recommendations for bag rate coverage will provide useful information to accommodate for settling. |
| <b>SETTLING</b>                           | Compression or compaction of insulation fibers caused by the weight of the material, vibration of structure, temperature, and humidity cycles.   |

**SERVICE RECORD**

| <b>DATE</b> | <b>MAINTENANCE PERFORMED</b> | <b>COMPONENTS REQUIRED</b> |
|-------------|------------------------------|----------------------------|
|             |                              |                            |



## 65 YEARS OF AMERICAN INGENUITY

**Made in the U.S.A.**

---

---

**KRENDL MACHINE COMPANY • 1201 SPENCERVILLE RD  
DELPHOS, OHIO 45833 • TELEPHONE 800-459-2069 • FAX 419-695-9301  
E - MAIL: [krendl@krendlmachine.com](mailto:krendl@krendlmachine.com) • WEB SITE: [www.krendlmachine.com](http://www.krendlmachine.com)**

---

---