



MAINTENANCE

BEARINGS: The bearings will need daily maintenance to enhance the life of the unit.

- 1.) Blow out insulation that gathers around bearings on roller assembly.
- 2.) Relubricate (moisten) bearings with WD-40 or any synthetic spray oil.

NOTE: Failure to do so will result in bearing or motor failure.

ROLLER: When the roller becomes loose and begins to wobble, it must be adjusted.

- 1.) Remove Belt Guard.
- 2.) Remove the belt from the handle end, then remove the belt from the Roller end.
- 3.) Loosen set screw on the Roller. (See diagram below)
- 4.) Tighten the locknut on each end of the Roller until there is no wobble (4 in.lbs.).

NOTE: Do not overtighten or the bearings will overheat and wear prematurely.

- 5.) Tighten the set screw on the Roller.
- 6.) Reinstall the belt.
- 7.) Reinstall the Belt Guard.

BELT TENSION: The belt will need retightened when it becomes loose.

- 1.) Loosen the two Arm Mounting bolts on the handle. (See diagram below)
- 2.) Loosen the Jamb Nut on the Adjustment Bolt.
- 3.) Turn the Adjustment Bolt until the belt is tight.
- 4.) Retighten the Jamb Nut on the Adjustment Bolt.
- 5.) Tighten the Arm Mounting bolts on the handle.

MOTOR BRUSHES: If there is arcing in the motor or a high amperage draw, the brushes might need replaced.

- 1.) Remove the two black plastic Brush Caps. (See diagram below)
- 2.) Remove Brush and Spring assemblies and install new Brush and Spring assemblies.
- 3.) Reinstall black plastic Brush Caps. **NOTE: Do not overtighten or the Brush Caps will crack and need replaced.**

NOTE: If wall scrubber is dropped or mishandled the roller shaft, roller bar, or motor could be damaged.

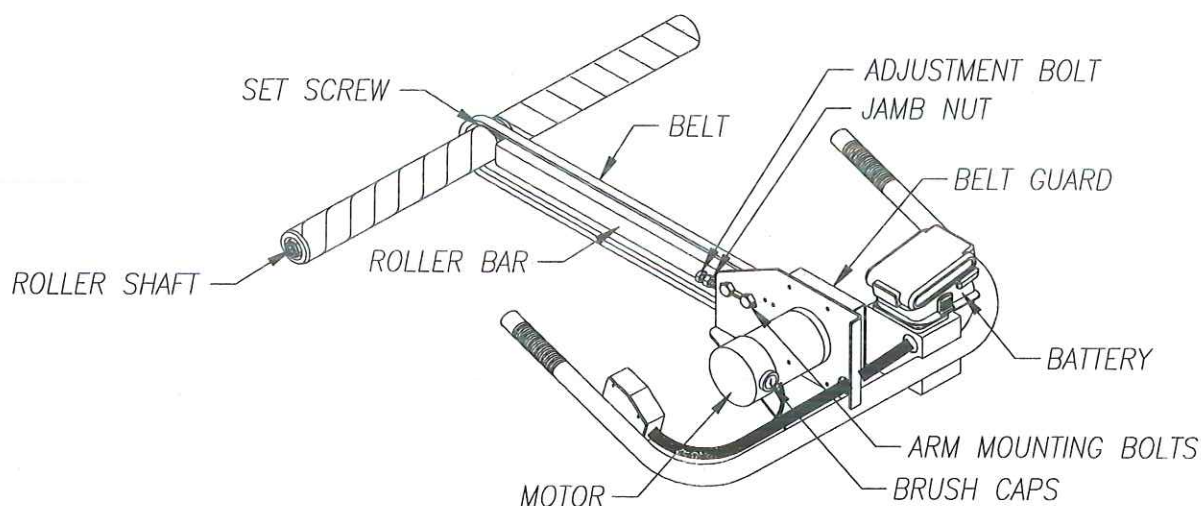

KRENDL MACHINE COMPANY

MODEL #349C-ABCD CORDLESS WALL SCRUBBER PARALLEL (EXTENSION) HANDLE PARTS LIST

STEEL PART NUMBER	ALUMINUM PART NUMBER	DESCRIPTION
WS-6C-R1	WS-6C-R1-A	FRAME, PARALLEL HANDLE, ALUMINUM
WS-8	WS-8-A	GUARD, BELT, ALUMINUM
WS-12	WS-12-A	ROLLER FRAME, TUBULAR 16", ALUMINUM
WS-12A	WS-12A-A	ROLLER FRAME, TUBULAR 28", ALUMINUM
	WS16A-ASSY	16" ALUMINUM ROLLER ARM ASSEMBLY
	WS28A-ASSY	28" ALUMINUM ROLLER ARM ASSEMBLY
WS-13	WS-13	V-BELT (#4L460)
WS-13A	WS-13A	V-BELT, 70"
WS-14	WS-14	GRIP, HANDLE, WS
WS-17	WS-17	BEARING, 1/2" BORE {4 REQUIRED}
WS-18	WS-18	HUB, OUTSIDE / DEEP {2 REQUIRED}
WS-19A	WS-19A	ROLLER TUBE, 1 1/4" x 12" {2 REQUIRED}
WS-19B	WS-19B	ROLLER TUBE, 1 1/4" x 8" {2 REQUIRED}
WS-20	WS-20	HUB, INSIDE / SHALLOW {2 REQUIRED}
WS-42A	WS-42A	BELTING, RIGHT 29" LONG {for 27" ROLLER}
WS-40A	WS-40A	BELTING, LEFT 29" LONG {for 27" ROLLER}
WS-42B	WS-42B	BELTING, RIGHT 21" LONG {for 18" ROLLER}
WS-40B	WS-40B	BELTING, LEFT 21" LONG {for 18" ROLLER}
WS-24A	WS-24A	SHAFT, 1/2" x 27"
WS-24B	WS-24B	SHAFT, 1/2" x 18"
WSR-A	WSR-A	ROLLER ASSEMBLY, 27" {COMPLETE}
WSR-B	WSR-B	ROLLER ASSEMBLY, 18" {COMPLETE}
WS-LA	WS-LA	ROLLER, 12", LEFT {COMPLETE}
WS-LB	WS-LB	ROLLER, 8", LEFT {COMPLETE}
WS-RA	WS-RA	ROLLER, 12", RIGHT {COMPLETE}
WS-RB	WS-RB	ROLLER, 8", RIGHT {COMPLETE}
WS-100	WS-100	DEWALT BATTERY CHARGER KIT {NOT SHOWN} {OPTIONAL}
WS-101	WS-101	DEWALT 18V TO 20V ADAPTER {OPTIONAL}
WS-102	WS-102	CHARGER DEWALT, 20V {OPTIONAL}
WS-103	WS-103	BATTERY, 20V DC, DCB203 {OPTIONAL}
WS-106	WS-106	MOTOR 1/8 H.P. 18V, DC
WS-108	WS-108	PULLEY, 2" Dia. x 12MM" BORE
WS-110	WS-110	BATTERY MARRIAGE PLATE
WS1206	WS1206	ROLLER MOUNT
WS1206-1	WS1206-1	ROLLER MOUNT SHIM
WS903	WS903	SCRAPER, PULLEY
141	141	CORD CLAMP, 3/8" {NOT SHOWN} {2 REQUIRED}
1536-2A	1536-2A	INSUL. 16 GA PLAST. 3/4 X 2 1/2 {NOT SHOWN} {2 REQUIRED}
1536-2	1536-2	INSUL. 16 GA PLAST. 1 1/2 X 2 1/2 {NOT SHOWN} {2 REQUIRED}
109066-9	109066-9	SWITCH, TOGGLE (DPDT)
1536-5-BWS	1536-5-BWS	HOUSING, SWITCH, CORDLESS
FN010	FN010	LOCK NUT, 1/2-13 {2 REQUIRED}
FN011	FN011	NUT, 5/16-18 HEX
FN019	FN019	N 5/16-18 FLANGE NUT {2 REQUIRED}
FSB042	FSB042	HEX BOLT, 5/16-18 x 1 1/2"
FSB077	FSB077	PPH 6-20 X 3/4 SELF TAP {4 REQUIRED}
FSB099	FSB099	SB 10-32 X 5/16 RMS {6 REQUIRED}
FSB100	FSB100	SB 10-32 X 1/2 PMS {4 REQUIRED}
FSB102	FSB102	SB 5/16-18 X 1 1/2 CMS {2 REQUIRED}
FSB106	FSB106	SB 8-32 X 3/8 SSS
FSB130	FSB130	SB 10-16 X 3/4 HHSM SELF DRILL {4 REQUIRED}
FSB305	FSB305	SB 10-32 X 1 FASTNER {2 REQUIRED}
FW002	FW002	W #10 LOCKWASHER
FW013	FW013	WASHER, 1/2" x 1/32" SHIM {2 REQUIRED}
RM-CT0775	RM-CT0775	CABLE TIES, 7 3/4", BLACK {NOT SHOWN}
RM-OTH205-MI	RM-OTH205-MI	TUBING, FLEX/SPLIT 3/8" {NOT SHOWN}